



# Applications Guide

---

## Engineered Smoke Control System *for TRACER SUMMIT™*



---

**BAS-APG001-EN**





# Applications Guide

---

## Engineered Smoke Control System *for TRACER SUMMIT™*





*Applications Guide, Engineered Smoke Control System for Tracer Summit™*

This guide and the information in it are the property of American Standard and may not be used or reproduced in whole or in part, without the written permission of American Standard. Trane, a business of American Standard, Inc., has a policy of continuous product and product data improvement and reserves the right to change design and specification without notice.

Use of the software contained in this package is provided under a software license agreement. Unauthorized use of the software or related materials discussed in this guide can result in civil damages and criminal penalties. The terms of this license are included with the compact disk. Please read them thoroughly.

Although Trane has tested the hardware and software described in this guide, no guarantee is offered that the hardware and software are error free.

Trane reserves the right to revise this publication at any time and to make changes to its content without obligation to notify any person of such revision or change.

Trane may have patents or patent applications covering items in this publication. By providing this document, Trane does not imply giving license to these patents.

™ ® The following are trademarks or registered trademarks of American Standard: Rover, Trane, and Tracer Summit.

™ ® The following are trademarks or registered trademarks of their respective companies or organizations: LonTalk and LonWorks from Echelon Corporation, National Electrical Code from the National Fire Protection Association.

Printed in the U.S.A.

© 2006 American Standard All rights reserved



## **NOTICE:**

Warnings and Cautions appear at appropriate sections throughout this manual. Read these carefully:

### **⚠WARNING**

Indicates a potentially hazardous situation, which, if not avoided, could result in death or serious injury.

### **⚠CAUTION**

Indicates a potentially hazardous situation, which, if not avoided, may result in minor or moderate injury. It may also be used to alert against unsafe practices.

### **CAUTION**

Indicates a situation that may result in equipment damage or property damage.

The following format and symbol conventions appear at appropriate sections throughout this manual:

### **IMPORTANT**

Alerts installer, servicer, or operator to potential actions that could cause the product or system to operate improperly but will not likely result in potential for damage.

---

**Note:**

A note may be used to make the reader aware of useful information, to clarify a point, or to describe options or alternatives.



# Contents

---

<b>Chapter 1</b>	<b>Smoke control overview . . . . .</b>	<b>1</b>
	Methods of smoke control . . . . .	2
	Compartmentation method . . . . .	2
	Dilution method . . . . .	2
	Pressurization method . . . . .	2
	Airflow method . . . . .	4
	Buoyancy method . . . . .	5
	Applications of smoke control methods . . . . .	5
	Zoned smoke control . . . . .	5
	Stairwell smoke control . . . . .	7
	Elevator shaft smoke control . . . . .	9
	Atrium smoke control . . . . .	10
	Underground building smoke control . . . . .	12
	Smoke detection and system activation . . . . .	12
	Zoned smoke control detection and activation . . . . .	13
	Stairwell smoke control detection and activation . . . . .	13
	Elevator smoke control detection and activation . . . . .	13
	Atrium smoke exhausting detection and activation . . . . .	13
	Design approaches to smoke control . . . . .	15
	No-smoke approach . . . . .	15
	Tenability approach . . . . .	15
	Dedicated system approach . . . . .	15
	Design considerations for smoke control . . . . .	16
	Plugholing . . . . .	16
	Smoke feedback . . . . .	17
<b>Chapter 2</b>	<b>Pre-installation considerations . . . . .</b>	<b>19</b>
	Zone operating modes . . . . .	19
	Normal mode . . . . .	20
	Alarm mode . . . . .	20
	Adjacent mode . . . . .	20
	Unaffected mode . . . . .	20
	Associated equipment . . . . .	20
	Fire alarm system equipment . . . . .	20
	Fire alarm control panel . . . . .	22

Smoke control system equipment . . . . .	23
Equipment supervision . . . . .	26
System testing . . . . .	27
Automatic weekly self-testing . . . . .	27
Manual periodic testing . . . . .	27
Alarm response . . . . .	27
Automatic smoke control matrix . . . . .	27
Response times . . . . .	29
Cable distance considerations . . . . .	29
<b>Chapter 3 Installation diagrams . . . . .</b>	<b>31</b>
Smoke control system overview . . . . .	31
System riser diagrams . . . . .	32
System termination diagrams . . . . .	33
Tracer MP581 to FSCS wiring . . . . .	34
Tracer MP581 to FACP wiring . . . . .	37
<b>Chapter 4 Installing the Tracer Summit BMTX BCU . . . . .</b>	<b>39</b>
Mounting the hardware . . . . .	39
Operating environment requirements . . . . .	39
Clearances . . . . .	40
Mounting the back of the enclosure . . . . .	42
Wiring high-voltage ac power . . . . .	43
EMI/RFI considerations . . . . .	46
Checking the earth ground . . . . .	46
Connecting the main circuit board . . . . .	48
Installing the door . . . . .	50
Transtector, Ethernet (UUKL nondedicated only), and LonTalk connections on the BMTX BCU . . . . .	51
<b>Chapter 5 Installing the Tracer MP581 programmable controller . . . . .</b>	<b>53</b>
Installation guidelines . . . . .	53
Specifications . . . . .	54
Selecting a mounting location . . . . .	55
Operating environment requirements . . . . .	55
Clearances and dimensions . . . . .	56
Mounting the back of the enclosure . . . . .	58
Wiring high-voltage ac power . . . . .	59



Circuit requirements . . . . .	59
Wiring high-voltage power . . . . .	60
EMI/RFI considerations . . . . .	62
Checking the earth ground . . . . .	62
Wiring inputs and outputs . . . . .	64
Input/output wiring guidelines . . . . .	64
Wire routing . . . . .	65
Providing low-voltage power for inputs and outputs . . . . .	65
Screw terminal locations . . . . .	66
Wiring universal inputs . . . . .	67
Wiring analog outputs . . . . .	68
Wiring binary outputs . . . . .	69
Checking binary inputs . . . . .	70
Checking outputs . . . . .	71
Checking binary outputs . . . . .	71
Checking 0–10 Vdc analog outputs . . . . .	71
Checking 0–20 mA analog outputs . . . . .	72
Wiring LonTalk to the Tracer MP581 . . . . .	74
Installing the circuit board . . . . .	76
Verifying operation and communication of the Tracer MP581 . . . . .	79
Service Pin button . . . . .	79
Interpreting LEDs . . . . .	79
Binary output LEDs . . . . .	80
Service LED . . . . .	80
Status LED . . . . .	81
Comm LED . . . . .	81
Installing the door . . . . .	82
Removing the door . . . . .	82
<b>Chapter 6 Installing the EX2 expansion module . . . . .</b>	<b>85</b>
Storage environment . . . . .	86
Mounting location . . . . .	86
Terminal strips . . . . .	87
Mounting the metal-enclosure module . . . . .	87
AC-power wiring . . . . .	88
Wiring AC-power to the metal-enclosure module . . . . .	89
I/O bus wiring . . . . .	91
Setting the I/O bus addresses . . . . .	93
Input/output terminal wiring . . . . .	93
Universal inputs . . . . .	94

Binary outputs . . . . .	94
Analog outputs (UUKL nondedicated only) . . . . .	94
Analog output and universal input setup . . . . .	94
Interpreting EX2 LEDs . . . . .	96
Binary output LEDs . . . . .	96
Status LED . . . . .	97
Communications LEDs . . . . .	97
<b>Chapter 7 Programming . . . . .</b>	<b>99</b>
Response times . . . . .	99
Operational priority . . . . .	100
Subsequent alarms . . . . .	101
Smoke alarm annunciation . . . . .	103
Weekly self-test of dedicated systems . . . . .	105
End process verification . . . . .	109
Communication watchdog . . . . .	112
Lamp test and audio alarm silence . . . . .	116
Nondedicated smoke purge . . . . .	118
Variable-air-volume system . . . . .	119
Constant-volume system . . . . .	119
UL-tested programs . . . . .	119
<b>Chapter 8 Network variable bindings . . . . .</b>	<b>121</b>
Overview . . . . .	121
Binding network variables . . . . .	121
Tracer MP580/581 bindings . . . . .	122
Receiving data . . . . .	122
Sending data . . . . .	122
Heartbeated network variables . . . . .	122
Custom bindings . . . . .	123
UUKL binding list (watchdog communication) . . . . .	123
UUKL binding list (smoke alarm status) . . . . .	126
UUKL binding list (FCSP override control) . . . . .	127
UUKL binding list (actuator Open/Close or On/Off status) . . . . .	128
UUKL binding list (actuator failure status) . . . . .	129
UUKL binding list (FSCP control) . . . . .	129
UUKL binding list (automatic self-test trigger and status) . . . . .	130
Custom binding report . . . . .	130
Understanding bindings . . . . .	130



Node .....	131
Binding types .....	131
Basic binding shapes and the hub/target system .....	131
Designing bindings .....	133
<b>Appendix A References.....</b>	<b>141</b>



**Contents**

## Chapter 1

# Smoke control overview

---

Smoke is one of the major problems created by a fire. Smoke threatens life and property, both in the immediate location of the fire and in locations remote from the fire. The objectives of smoke control include:

- Maintain reduced-risk escape route environments
- Diminish smoke migration to other building spaces
- Reduce property loss
- Provide conditions that assist the fire service
- Aid in post-fire smoke removal

Smoke consists of airborne solid and liquid particulates, gases formed during combustion, and the air supporting the particulates and gases. Smoke control manages smoke movement to reduce the threat to life and property. This chapter describes:

- Methods of smoke control
- Applications of smoke control methods
- Smoke detection and system activation
- Design approaches to smoke control
- Design considerations for smoke control

## **Methods of smoke control**

Smoke control system designers use five methods to manage smoke. They use the methods individually or in combination. The specific methods used determine the standards of design analysis, performance criteria, acceptance tests, and routine tests. The methods of smoke control consist of: compartmentation, dilution, pressurization, air flow, and buoyancy.

### **Compartmentation method**

The compartmentation method provides passive smoke protection to spaces remote from a fire. The method employs walls, partitions, floors, doors, smoke barriers, smoke dampers, and other fixed and mechanical barriers. Smoke control system designers often use the compartmentation method in combination with the pressurization method.

### **Dilution method**

The dilution method clears smoke from spaces remote from a fire. The method supplies outside air through the HVAC system to dilute smoke. Using this method helps to maintain acceptable gas and particulate concentrations in compartments subject to smoke infiltration from adjacent compartments. In addition, the fire service can employ the dilution method to remove smoke after extinguishing a fire. Smoke dilution is also called smoke purging, smoke removal, or smoke extraction.

Within a fire compartment, however, dilution may not result in any significant improvement in air quality. HVAC systems promote a considerable degree of air mixing within the spaces they serve and building fires can produce very large quantities of smoke. Also, dilution within a fire compartment supplies increased oxygen to a fire.

### **Pressurization method**

The pressurization method protects refuge spaces and exit routes. The method employs a pressure difference across a barrier to control smoke movement (Figure 1 on page 3). The high-pressure side of the barrier is either the refuge area or an exit route. The low-pressure side is exposed to smoke. Airflow from the high-pressure side to the low-pressure side (through construction cracks and gaps around doors) prevents smoke infiltration. A path that channels smoke from the low-pressure side to the outside ensures that gas expansion pressures do not become a problem. A top-vented elevator shaft or a fan-powered exhaust can provide the path.

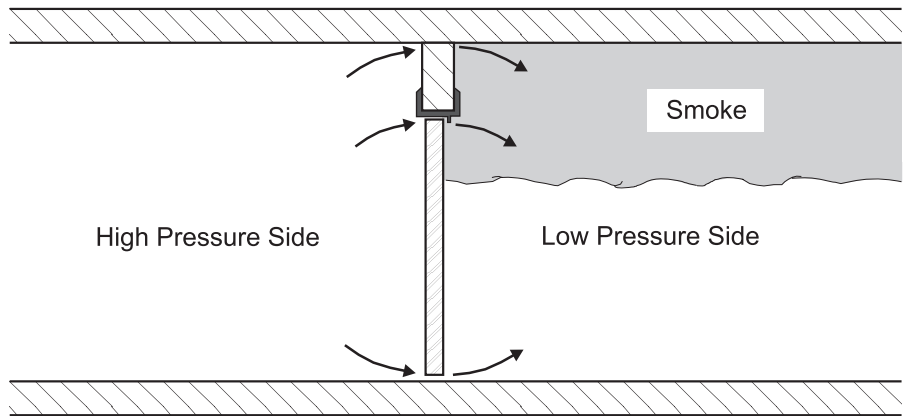
**Figure 1: Sample pressure difference across a barrier**


Table 1 provides the National Fire Protection Association (NFPA) recommended minimum pressure difference between the high-pressure side and the low-pressure side.

**Table 1: Recommended minimum pressure difference**

Building type	Ceiling height (ft [m])	Minimum pressure difference (In.w.c. [Pa])
Sprinklered	Any	0.05 (12.4)
Non-sprinklered	9 (2.7)	0.10 (24.9)
Non-sprinklered	15 (4.6)	0.14 (34.8)
Non-sprinklered	21 (6.4)	0.18 (44.8)

Notes:

- The minimum pressure difference column provides the pressure difference between the high pressure side and the low-pressure side.
- The minimum pressure difference values incorporate the pressure induced by the buoyancy of hot smoke.
- A smoke control system should maintain the minimum pressure differences regardless of stack effect and wind.
- The minimum pressure difference values are based on recommendations in NFPA 92A (NFPA 2000, *Recommended Practice for Smoke Control Systems*).
- *In.w.c.* is inches of water column.
- *Pa* is Pascals.

Table 2 on page 4 provides the NFPA recommended maximum allowable pressure difference across doors. The listed pressure differences take into account the door closer force and door width.

**Table 2: Maximum allowable pressure differences across doors**

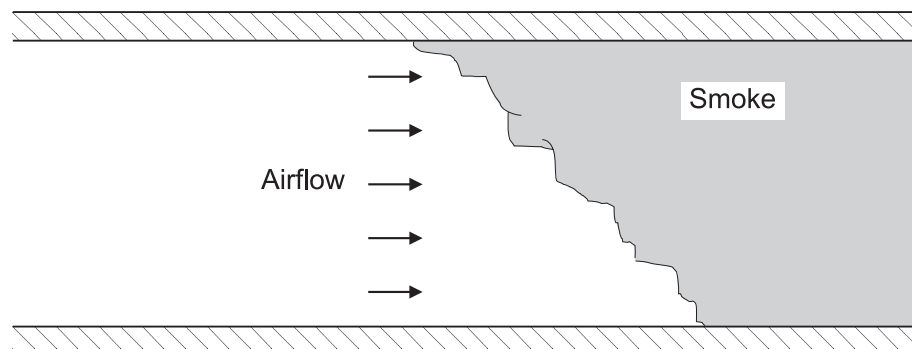
Door closer force (lb. [N])	Door width (in. [m])				
	32 (0.813)	36 (0.914)	40 (1.02)	44 (1.12)	46 (1.17)
	Pressure difference (In.w.c. [Pa])				
6 (26.7)	0.45 (112.0)	0.40 (99.5)	0.37 (92.1)	0.34 (84.6)	0.31 (77.1)
8 (35.6)	0.41 (102.0)	0.37 (92.1)	0.34 (84.5)	0.31 (77.1)	0.28 (69.7)
10 (44.5)	0.37 (92.1)	0.34 (84.5)	0.30 (74.6)	0.28 (69.7)	0.26 (64.7)
12 (53.4)	0.34 (84.5)	0.30 (74.6)	0.27 (67.2)	0.25 (62.2)	0.23 (57.2)
14 (62.3)	0.30 (74.6)	0.27 (67.2)	0.24 (59.7)	0.22 (45.7)	0.21 (52.2)

Notes:

- Total door opening force is 30 lb. (133 N); door height is 80 in. (2.03 m). NFPA 101 (NFPA 2003, *Life Safety Code*) recommends the door opening force.
- *N* is Newton.
- *m* is meter.
- *In.w.c.* is inches of water column.
- *Pa* is Pascal.
- The pressure difference values are based on recommendations in NFPA 92A (NFPA 2000, *Recommended Practice for Smoke Control Systems*).

## Airflow method

The airflow method controls smoke in spaces that have barriers with one or more large openings. It is used to manage smoke in subway, railroad, and highway tunnels. The method employs air velocity across or between barriers to control smoke movement (Figure 2).

**Figure 2: Sample airflow method**




A disadvantage of the airflow method is that it supplies increased oxygen to a fire. Within buildings, the airflow method must be used with great caution. The airflow required to control a wastebasket fire has sufficient oxygen to support a fire 70 times larger than the wastebasket fire. The airflow method is best applied after fire suppression or in buildings with restricted fuel. For more information on airflow, oxygen, and combustion, refer to Huggett, C. 1980, *Estimation of Rate of Heat Release by Means of Oxygen Consumption Measurements, Fire and Materials*.

### **Buoyancy method**

The buoyancy method clears smoke from large volume spaces with high ceilings. The method employs paths to the outside and relies on hot combustion gases rising to the highest level in a space. At the high point, either a powered smoke exhausting system or a non-powered smoke venting system clears the smoke.

## **Applications of smoke control methods**

Applying the methods of smoke control to spaces within a building provides a building smoke control system. Smoke control methods are most commonly applied to building spaces to provide zoned, stairwell, elevator shaft, and atrium smoke control.

---

**Note:**

It is beyond the scope of this user guide to provide mathematical design analysis information for smoke control. For references to design analysis information, see Appendix A, References.

### **Zoned smoke control**

Zoned smoke control uses compartmentation and pressurization to limit smoke movement within a building. Typically, a building consists of a number of smoke control zones. Barriers (partitions, doors, ceilings, and floors) separate the zones. Each floor of a building is usually a separate zone (Figure 3 on page 6). However, a zone can consist of more than one floor, or a floor can consist of more than one zone.

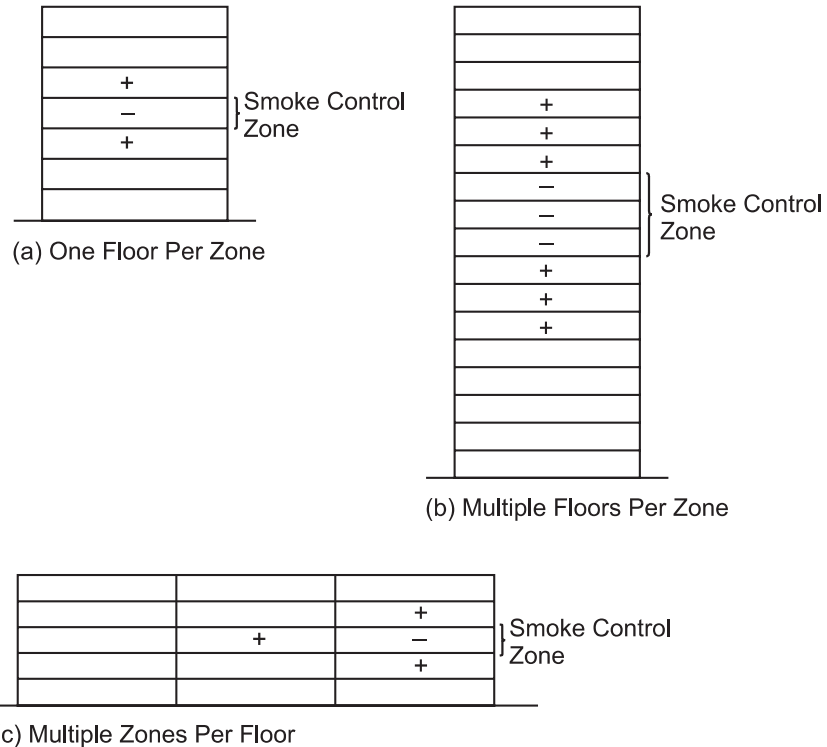
The zone in which the smoke is detected is the smoke control zone. Zones next to the smoke control zone are adjacent zones. Zones not next to the smoke control zone are unaffected zones.

Pressure differences produced by fans limit smoke movement to adjacent and unaffected zones. The system may pressurize adjacent zones and leave all unaffected zones in normal operation (Figure 3(a) and Figure 3(c), page 6). Pressurizing adjacent zones creates a pressure sandwich. Or, the system may pressurize adjacent zones and some unaffected zones (Figure 3(b), page 6). In either case, the system exhausts the smoke control zone, putting it at a negative pressure, relative to adjacent zones.

## Chapter 1 Smoke control overview

Zoned smoke control cannot limit the spread of smoke within the smoke control zone. Consequently, occupants of the smoke control zone must evacuate as soon as possible after fire detection.

**Figure 3: Sample arrangements of smoke control zones**

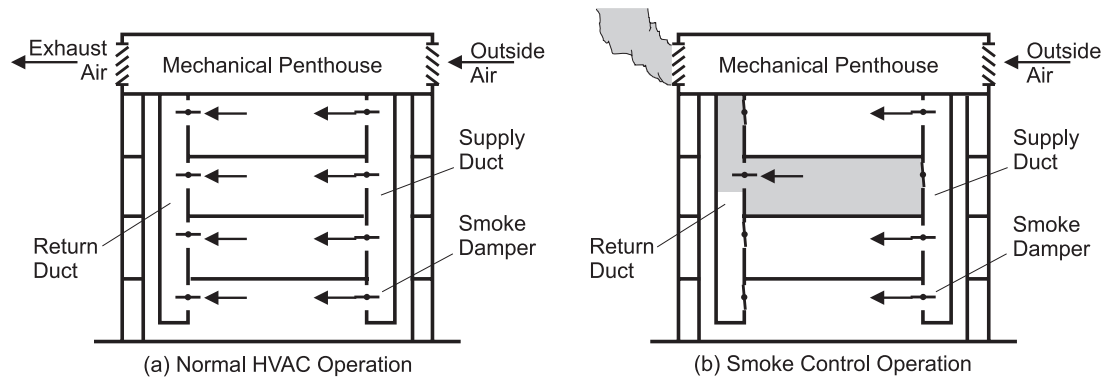


+ : Represents high-pressure zone

- : Represents low-pressure zone

When an HVAC system serves multiple floors (Figure 4 on page 7) and each floor is a separate zone, the following sequence provides smoke control:

1. In the smoke control zone, the smoke damper in the supply duct closes and the smoke damper in the return duct opens.
2. In adjacent and/or unaffected zones, the smoke dampers in the return ducts close and smoke dampers in the supply ducts open.
3. If the system has a return air damper, it closes.
4. Supply and return fans activate.

**Figure 4: Sample HVAC operation during smoke control**

**Note:**

For simplicity, Figure 4 does not show the ducts on each floor or the penthouse equipment.

When an HVAC system serves only one smoke control zone, the following sequence provides smoke control:

1. In the smoke control zone, the return/exhaust fan activates, the supply fan deactivates.
2. The return air damper closes, and the exhaust damper opens (optionally, the outside air damper closes).
3. In the no-smoke zone, the return/exhaust fan deactivates, the supply fan activates.
4. The return air damper closes, and the outside air damper opens (optionally, the exhaust air damper closes).

### Stairwell smoke control

Stairwell smoke control uses pressurization to prevent smoke migration through stairwells to floors remote from the source of the smoke. Secondly, it provides a staging area for fire fighters.

In the smoke control zone, a pressurized stairwell maintains a positive pressure difference across closed stairwell doors to limit smoke infiltration to the stairwell. Stairwell smoke control employs one or more of these design techniques: compensated pressurization, non-compensated pressurization, single injection pressurization, and multiple injection pressurization.

#### Compensated pressurization technique

The compensated stairwell pressurization technique adjusts air pressure to compensate for various combinations of open and closed stairwell access doors. The technique maintains constant positive pressure differences across openings. To compensate for pressure changes, it either employs modulated supply airflow or over-pressure relief.

## Chapter 1 Smoke control overview

If the technique employs modulated supply airflow, a fan provides at least minimum pressure when all stairwell access doors are open. Either a single-speed fan with modulating bypass dampers or a variable frequency drive varies the flow of air into the stairwell to compensate for pressure changes.

If the technique employs over-pressure relief, a damper or fan relieves air to the outside to maintain constant pressure in the stairwell. The amount of air relieved depends on the air pressure in the stairwell. A barometric damper, a motor-operated damper, or an exhaust fan can be used to maintain the air pressure.

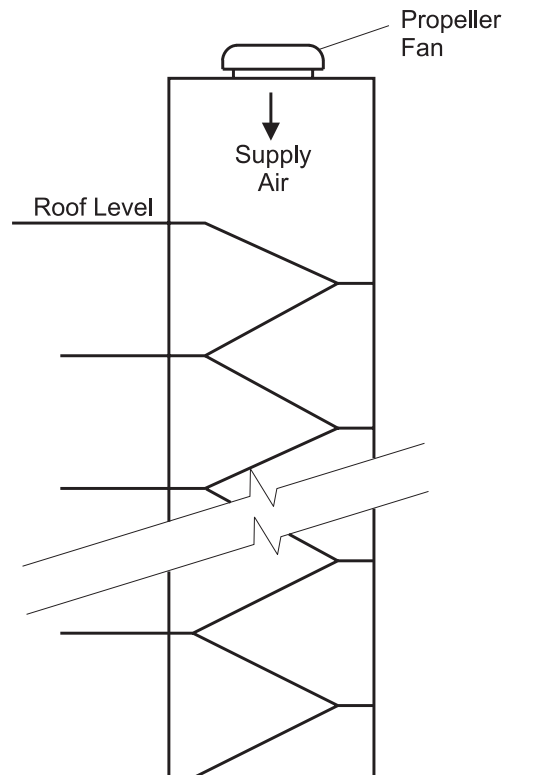
### Non-compensated pressurization technique

The non-compensated pressurization technique provides a constant volume of pressurization air. The level of pressurization depends on the state of the stairwell access doors. When access doors open, the pressure in the stairwell lowers. When access doors close, the pressure raises. One or more single-speed fans provide pressurization air (Figure 5).

Non-compensated stairwell pressurization works best when:

- Stairwells are in a lightly populated building (for example: telephone exchanges and luxury apartments).
- Stairwell access doors are usually closed, but when used, remain open only a few seconds.

**Figure 5: Sample non-compensated system**



### Single and multiple injection pressurization techniques

The single injection and multiple injection techniques provide pressurization air to a stairwell (Figure 6). Both techniques use one or more pressurization fans located at ground level, roof level, or any location in between.

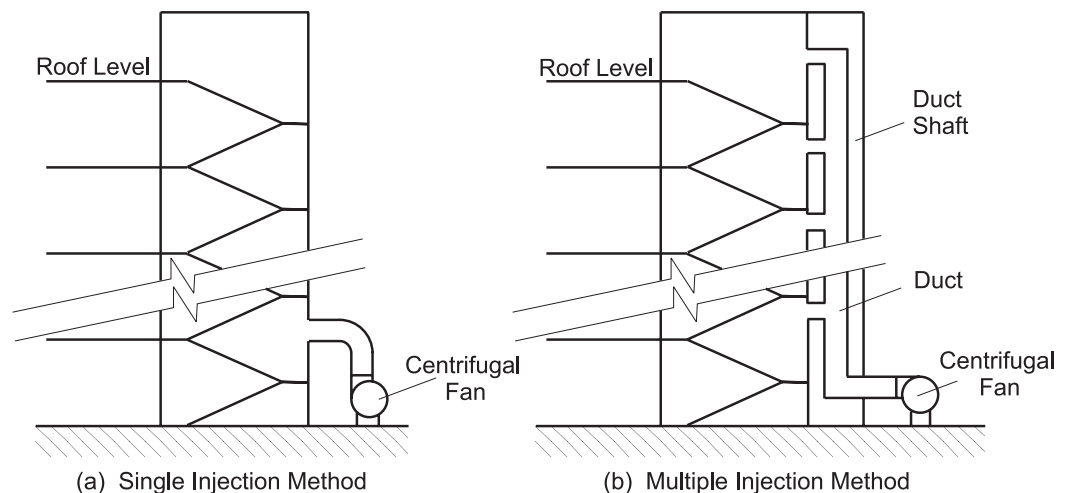
The single injection technique supplies pressurization air to the stairwell from one location.

#### IMPORTANT

**The single injection technique can fail when stairwell access doors are open near the air supply injection point. Pressurization air will escape and the fan will fail to maintain a positive pressure difference across access doors farther from the injection point.**

The multiple injection technique supplies pressurization air to the stairwell from more than one location. When access doors are open near one injection point, pressurization air escapes. However, other injection points maintain positive pressure differences across the remaining access doors.

**Figure 6: Sample single and multiple injection methods**



### Elevator shaft smoke control

Elevator shaft smoke control uses pressurization to prevent smoke migration through elevator shafts to floors remote from the source of the smoke. Elevator shaft smoke control is similar to stairwell smoke control. The stairwell pressurization techniques described previously are applicable to elevator shaft pressurization.

Designating an elevator as a fire exit route is an acceptable, though not typical, practice. NFPA 101 (NFPA 2003, *Life Safety Code*) allows elevators to be second fire exit routes from air traffic control towers. For

more information about elevator shaft smoke control, refer to Klote, J.K., and Milke, J.A. (*Design of Smoke Management Systems*, 1992).

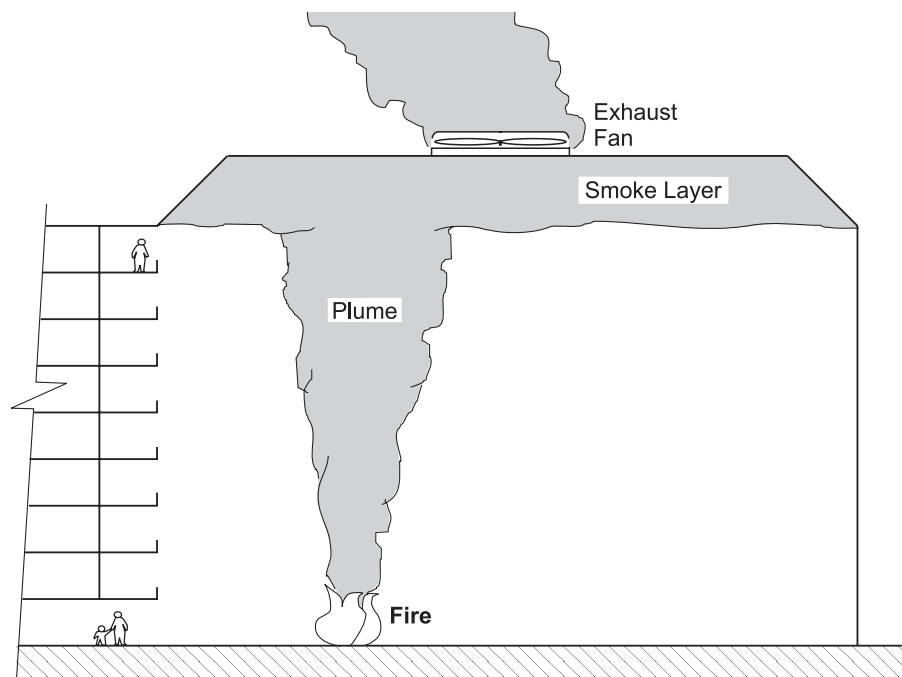
## Atrium smoke control

Atrium smoke control uses buoyancy to manage smoke in large-volume spaces with high ceilings. The buoyancy of hot smoke causes a plume of smoke to rise and form a smoke layer under the atrium ceiling. NFPA 92B (NFPA 2000, *Guide for Smoke Management Systems in Malls, Atria, and Large Areas*) addresses smoke control for atria, malls, and large areas. Atrium smoke control techniques consist of smoke exhausting, natural smoke venting, and smoke filling.

### Smoke exhausting technique

The smoke exhausting technique employs fans to exhaust smoke from the smoke layer under the ceiling. Exhausting prevents the smoke layer from descending and coming into contact with the occupants of the atrium (Figure 7). Effective smoke removal requires providing makeup air to the space. Makeup air replaces the air that is exhausted by the fans. If makeup air is not introduced, the space will develop a negative pressure, which will restrict smoke movement.

**Figure 7: Sample atrium smoke exhausting technique**



### Natural smoke venting technique

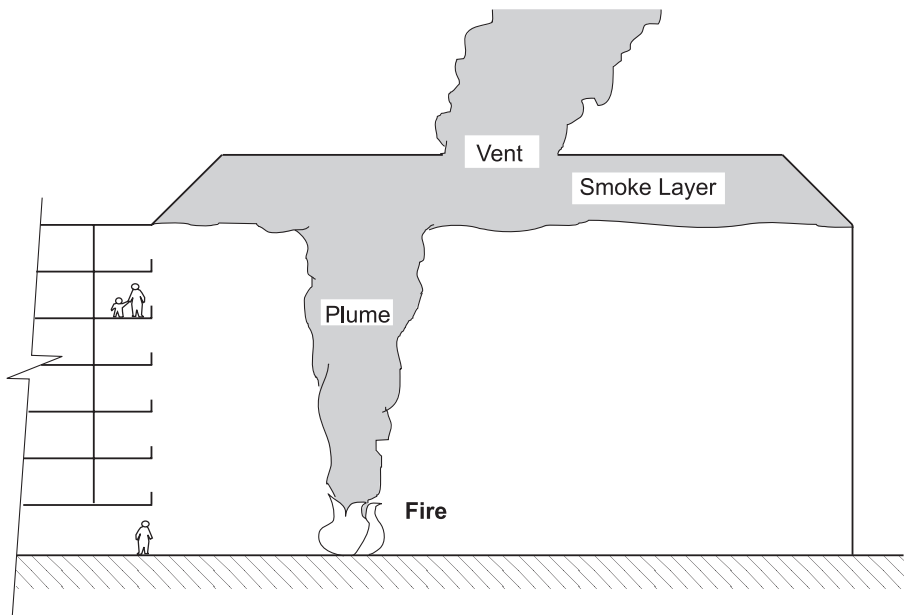
The natural smoke venting technique employs vents in the atrium ceiling or high on the atrium walls to let smoke flow out without the aid of fans (Figure 8). The applicability of natural venting depends primarily on the size of the atrium, the outside temperature, and the wind conditions. When smoke is detected, all vents open simultaneously. The flow rate through a natural vent depends on the size of the vent, the depth of the smoke layer, and the temperature of the smoke.

---

**Note:**

Thermally activated vents are not appropriate for natural venting because of the time delay for opening.

**Figure 8: Sample natural smoke venting technique**



### Smoke filling technique

The smoke filling technique allows smoke to collect at the ceiling. Without fans to exhaust the smoke, the smoke layer grows thicker and descends. Atrium smoke filling is viable when an atrium is of such size that the time needed for the descending smoke to reach the occupants is greater than the time needed for evacuation.

People movement calculations determine evacuation time. For information on people-movement calculations, refer to SFPE 1995, *Fire Protection Engineering Handbook*.

## Underground building smoke control

The smoke control objective for underground buildings is to contain and remove smoke from the alarm zone. The smoke control system fully exhausts the alarm zone and provides makeup air to replace the exhausted air.

Setup and zoning of the smoke detectors is part of the fire alarm system engineering effort. The fire alarm system signals the smoke control system to start automatic smoke control operations.

In NFPA 101 (NFPA 2003, *Life Safety Code*), chapter 11.7 states that an underground building with over 100 occupants must have an automatic smoke venting system. Chapter 14.3, for new educational occupancies, provides smoke zoning requirements. Chapter 12.4.3.3 states that automatic smoke control must be initiated when two smoke detectors in a smoke zone activate. Chapter 12.4.3.3 states that the system must be capable of at least 6 air changes per hour.

## Smoke detection and system activation

The appropriate smoke detection and system activation approach depends on the specifics of the smoke control system and on the code requirements. Automatic activation has the advantage over manual activation. Automatic activation provides fast and accurate response. Each smoke control application has detection and activation requirements:

- Zoned smoke control
- Stairwell smoke control
- Elevator smoke control
- Atrium smoke exhaust

---

**Note:**

Smoke detectors located in HVAC ducts should not be the primary means of smoke control activation. Duct detectors have long response times and exhibit degraded reliability when clogged by airborne particles. However, a duct detector signal may be used in addition to a primary means of activation. For more information, refer to Tamura, G.T., *Smoke Movement & Control in High-Rise Buildings*.



## **Zoned smoke control detection and activation**

Zoned smoke control activation occurs on a signal from either a sprinkler water flow switch or a heat detector. For maximum benefit, the zoned smoke control system should only respond to the first alarm. Two design techniques that prevent detection of smoke in zones other than the first zone reporting are:

- Not activating smoke control on smoke detector signals
- Activating smoke control on signals from two separate smoke detectors located in the same zone

---

**Note:**

Zoned smoke control should not activate on a signal from a manual pull station (pull box). If pull box activation does not occur in the zone that contains the fire, activation incorrectly identifies the smoke zone.

## **Stairwell smoke control detection and activation**

Stairwell smoke control activation occurs on an alarm signal from any device, including sprinkler water flow switches, heat detectors, smoke detectors, and manual pull stations (pull boxes). Most stairwell smoke control systems operate in the same manner regardless of the source of the alarm signal.

## **Elevator smoke control detection and activation**

Elevator smoke control activation occurs on an alarm signal from any device, including sprinkler water flow switches, heat detectors, smoke detectors, and manual pull stations (pull boxes). Most elevator smoke control systems operate in the same manner regardless of the source of the alarm signal.

---

**Note:**

The description of elevator smoke control detection and activation does not apply to pressurization systems for elevators intended for occupant evacuation.

## **Atrium smoke exhausting detection and activation**

Atrium smoke exhausting activation occurs on a signal from a beam smoke detector. A beam smoke detector consists of a light beam transmitter and a light beam sensor. Typically, the transmitter and the sensor are located apart from each other. However, when located together, the transmitter sends its beam to the opposite side of the atrium. At the opposite side, the beam reflects back to the sensor.

---

**Note:**

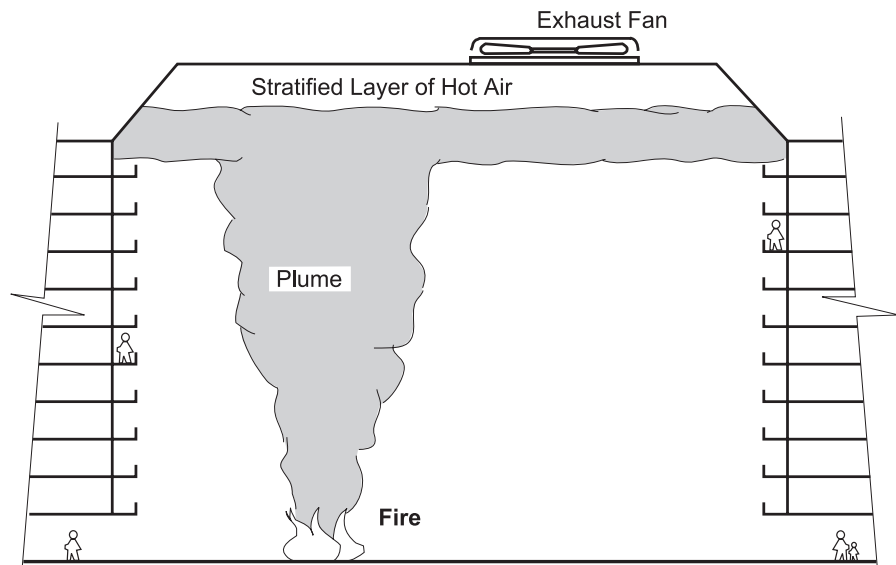
Atrium smoke control should not activate on a signal from a manual pull station (pull box). Atrium smoke exhaust systems have different operating modes depending on fire location.

**Note:**

Atrium smoke control should not activate on signals from sprinkler water flow switches or heat detectors. Since the temperature of a smoke plume decreases with height, activation by these devices may not provide reliable results.

Beam smoke detectors minimize interference problems created by stratified hot air under atrium ceilings. On hot days or days with a high solar load on the atrium roof, a hot layer of air may form under the ceiling. The layer can exceed 120° F (50° C). The smoke from an atrium fire may not be hot enough to penetrate the layer and reach ceiling-mounted smoke detectors (Figure 9).

Beam-detector installation typically conforms to one of two configurations: vertical grid or horizontal grid.

**Figure 9: Sample stratification**

**Vertical grid**

The vertical grid is the most common beam detector configuration. A number of beam detectors, located at different levels under the ceiling, detect the formation and thickening of a smoke layer. The bottom of the grid is at the lowest expected smoke stratification level.

**Horizontal grid**

The horizontal grid is an alternate beam detector configuration. A number of beam detectors, located at different levels under the ceiling, detect the rising smoke plume. Beam detectors are located:

- Below the lowest expected smoke stratification level
- Close enough to each other to ensure intersection with the plume

## **Design approaches to smoke control**

Smoke control methods provide a mechanical means of directing smoke movement in an enclosed space. The application of one or more methods to a building provides a building smoke control system. Design approaches to smoke control include the no smoke, tenability, and dedicated system approaches.

### **No-smoke approach**

The no-smoke approach provides a smoke control system that prevents smoke from coming into contact with people or property. Almost all smoke control systems are based on the no-smoke approach.

While the objective is to eliminate all smoke, some smoke occurs in protected spaces. By molecular diffusion, minute quantities of smoke travel against pressurization and airflow. These very low concentrations of airborne combustion products are detected by their odor. These and higher levels of diffused contaminants may not result in high-risk conditions.

### **Tenability approach**

The tenability approach provides a smoke control system that allows smoke to come into contact with occupants. However, in this approach, the smoke control system dilutes the by-products of combustion before they come into contact with people. In atria applications, the natural mixing of air into a smoke plume can result in significant dilution.

Tenability criteria vary with the application but may include:

- Exposure to toxic gases
- Exposure to heat
- Visibility

### **Dedicated system approach**

The dedicated system approach, such as stairwell and elevator smoke control, provides a system that has the sole purpose of managing smoke. It does not function during normal building comfort control.

The advantages of the dedicated system approach include:

- The interface is simple, since there are few components to bypass.
- Modification of controls after installation is unlikely.
- Easy operation and control.
- Limited reliance on other building systems.

The disadvantages of the dedicated system approach include:

- Component failures may go undiscovered since they do not affect normal building comfort control.
- Building systems may require more physical space.

## Design considerations for smoke control

Two occurrences will hinder smoke control:

- Plugholing
- Smoke feedback

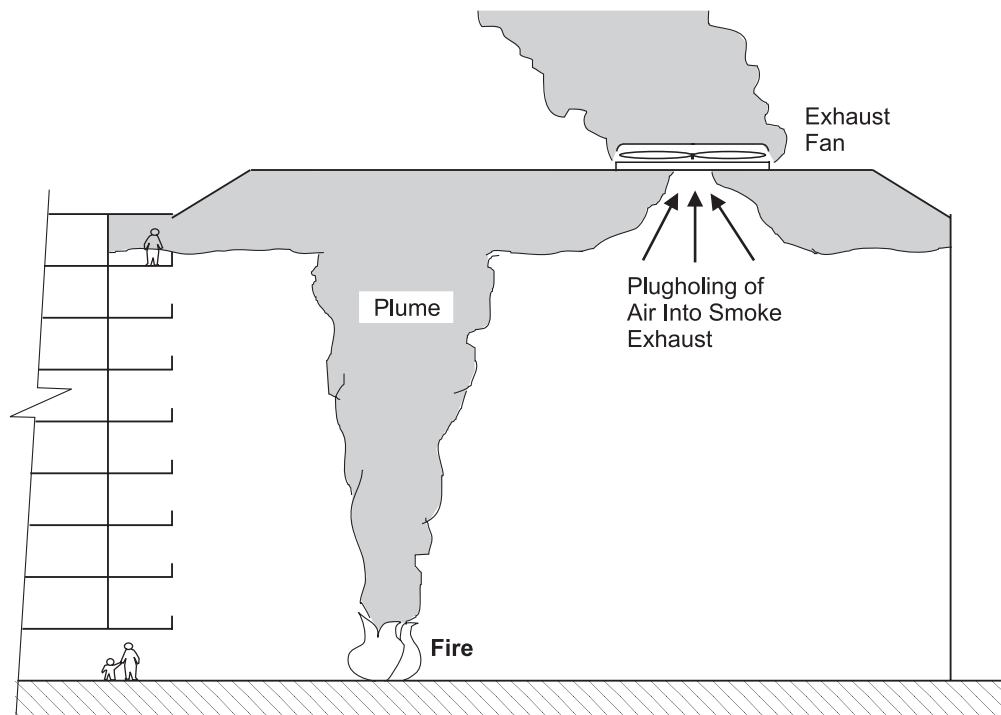
Smoke control systems should be designed to address the problems that are caused by plugholing and smoke feedback.

### Plugholing

Plugholing occurs when an exhaust fan pulls fresh air into the smoke exhaust (Figure 10). Plugholing decreases the smoke exhaust and increases the smoke layer depth. It has the potential of exposing occupants to smoke.

The maximum flow of smoke ( $Q_{\max}$ ) exhausted without plugholing depends on the depth of the smoke layer and the temperature of the smoke. If the required total smoke exhaust is greater than  $Q_{\max}$ , additional exhaust vents will eliminate plugholing. The distance between vents must be great enough that the air and smoke flow near one vent does not affect the air and smoke flow near another vent.

**Figure 10: Sample plugholing**



## **Smoke feedback**

Smoke feedback occurs when smoke enters a pressurization fan intake and flows into protected spaces. Design techniques reduce the probability of smoke feedback:

- Supply air intakes located below openings from which smoke might flow, such as building exhausts, smoke shaft outlets and elevator vents.
- Automatic shutdown capability to stop the system in the event of smoke feedback.

For more information on smoke feedback, refer to SFPE 1995, *Fire Protection Engineering Handbook*.



*Chapter 1 Smoke control overview*

## Chapter 2

# Pre-installation considerations

---

This chapter provides considerations that must be given prior to installing an engineered smoke control system. The pre-installation considerations are:

- Zone operating modes
- Associated equipment
- Equipment supervision
- System testing
- Alarm response
- Automatic smoke control matrix
- Response times

---

**Note:**

In this chapter, the application of the smoke control system as a zoned system is for general practice and conforms to national codes and publications. In all cases, the local *authority having jurisdiction* (AHJ) has the authority to modify requirements.

**IMPORTANT**

**The local AHJ must approve the proposed system before installation begins.**

## Zone operating modes

Zone operating modes are a pre-installation consideration. The design of a building smoke control system is the responsibility of the building architects and engineers. In the National Fire Protection Association (NFPA) publication NFPA 101 (NFPA 2003, *Life Safety Code*), chapter 11.8 provides general high rise building requirements. Chapter 12–42 provides high-rise building requirements based on type of occupancy. Both chapters may apply to a specific building.

Understanding the smoke control system operating modes enables the effective layout of system controls. One of four operating modes governs each zone: normal, alarm, adjacent, or unaffected.

## **Normal mode**

A zone is in normal mode when no fire, smoke, or sprinkler alarms are present in the building. In some zoning systems, a zone may be in normal mode if an alarm condition is present in the building but the zone is not affected. In normal mode, the smoke control system is inactive.

## **Alarm mode**

A zone is in alarm mode when it is the origin of the first fire, smoke, or sprinkler alarm. In alarm mode, the smoke control system operates fans and dampers to protect adjacent and unaffected zones and provide a smoke exhaust route for the alarm zone.

## **Adjacent mode**

A zone is in adjacent mode when it is next to the alarm zone. However, in some zoning systems, zones that are not next to the alarm zone may be designated as adjacent zones. Other zoning systems may designate all non-alarm zones as adjacent zones. Codes do not state which zones are adjacent. In adjacent mode, the smoke control system sets fans and dampers to pressurize adjacent zones in order to contain the smoke in the alarm zone.

## **Unaffected mode**

A zone is in unaffected mode when it is neither the alarm zone nor an adjacent zone and an alarm is present in the building. In large buildings, there may be many zones that are not near the alarm zone. Codes do not state which zones are unaffected. In unaffected mode, the smoke control system may shut down and isolate unaffected zones. Or, the smoke control system may allow unaffected zones to operate in normal mode. Actual system operation depends on the design of the smoke control system.

## **Associated equipment**

Equipment associated with the smoke control system design is a pre-installation consideration prior to setting up the smoke control system controls. Associated equipment includes: fire alarm system equipment, fire alarm control panel, firefighter's smoke control station, and smoke control system equipment.

### **Fire alarm system equipment**

The building fire alarm system is responsible for detecting an alarm condition, alerting occupants by audible and visual means, and signaling the smoke control system. Fire alarm system equipment includes: area,



beam, and duct smoke detectors; manual pull stations; and sprinkler flow devices.

---

**Note:**

Fire alarm system equipment is neither furnished nor installed by Trane.

**Area smoke detectors**

Area smoke detectors detect the presence of smoke at the ceiling. When activated, an area smoke detector signals the fire alarm system. The zoning of area smoke detectors must reflect the zoning of the building.

---

**Note:**

Under certain conditions, heat detectors or heat with rate of rise detectors are preferable to area smoke detectors.

**Beam smoke detectors**

Beam smoke detectors detect the presence of smoke beneath the ceiling. When activated, a beam smoke detector signals the fire alarm system. In atrium applications, beam detectors may replace area smoke detectors. Beam smoke detectors minimize interference problems created by stratified hot air under the atrium ceiling.

**Duct smoke detectors**

Duct smoke detectors detect smoke in building air-distribution system ductwork. When smoke is present, a signal from the detector deactivates the fans in the system in which the detector is installed. *However, smoke control system commands must override fan deactivation by a duct smoke detector.*

In NFPA 90A (NFPA 2002, *Standard for the Installation of Air Conditioning and Ventilating Systems*), section 6.4.2.1 provides the requirements for duct smoke detectors. Supply duct smoke detectors must be located downstream of the system filters and ahead of any branch connection. In mixing systems, this is usually after the return air connection. Duct smoke detectors may be required in the supply duct of all air-handling systems greater than 2000 cubic feet per minute (CFM) and at each floor with a return air volume greater than 15,000 CFM.

Two exceptions limit the use of duct smoke detectors:

- Duct smoke detectors are not required in 100% exhaust air systems.
- Duct smoke detector use is limited if area smoke detectors cover the entire space served by the return air distribution. Since area smoke detectors usually cover entire floors, the typical system only requires one duct smoke detector in the common return duct.

**Manual pull stations**

Manual pull stations enable occupants to report a fire. When activated, a manual pull station signals the fire alarm system. A manual pull station alarm must not initiate the automatic operation of the smoke control

## Chapter 2 Pre-installation considerations

system, since a pull station is not necessarily activated in the zone that contains the smoke or fire.

### **Sprinkler flow devices**

Fire alarm system equipment may include two types of sprinkler flow devices: sprinkler flow switches and tamper switches.

Sprinkler flow switches, installed in fire sprinkler lines, notify the fire alarm control panel (FACP) of flow in the sprinkler lines. The FACP transmits an alarm to the smoke control system. The smoke control system may initiate automatic smoke control from the alarm. Sprinkler zones must coincide with the zone layout of the building and the zoning of the FACP.

Tamper switches are installed on manual shutoff valves in the fire sprinkler system. The switches provide a supervisory alarm signal to the fire alarm system if the shutoff valve closes. Alarms activated by tamper switches must not initiate the automatic operation of the smoke control system.

### **Fire alarm control panel**

The FACP receives alarm signals. If the FACP receives an alarm, it notifies the smoke control system of the alarm and the alarm location. The zone layout of the FACP must match the zone layout of the building to ensure that the FACP is capable of sending accurate signals to the smoke control system. The mechanical and electrical consulting engineers coordinate the building zone layout to the FACP layout to ensure a proper interface.

#### **Firefighter's smoke control station**

The firefighter's smoke control station (FSCS) enables firefighters to take manual control of the smoke control system. The FSCS must be located in an easily accessible but secure location. The normal location is near the FACP.

### **IMPORTANT**

**The FSCS must be listed by Underwriters Laboratories (UL) as suitable for enabling firefighters to take manual control of the smoke control system.**

Commands from the FSCS control panel are the highest priority commands in the system. They override automatic control of smoke control system components.

The FSCS provides a graphic representation of the building. It shows smoke control zones and associated smoke control mechanical equipment. The panel includes: lights, an audible trouble LED, and manual switches.

### Lights

The FSCS provides lights that show the mode of each zone and the status of each piece of smoke control mechanical equipment. The status lights must conform to a specific color code scheme (Table 3).

**Table 3. Pilot lamp color codes**

Color	Description
Green	Fan On or damper Open
Red	Fan Off or damper Closed
Yellow (or Amber)	Verification of Operation Status light. Fan or damper not in commanded position.

### Audible trouble indicator

The FSCS may provide an audible trouble indicator with a silence switch. If provided, the indicator alerts personnel to system trouble.

### Manual switches

The FSCS provides manual switches that operate smoke control system fans and dampers. Normally, there is one manual switch for each piece of equipment. However, in complex smoke control systems that have very large fan systems, one switch may operate more than one piece of equipment. This allows the smoke control system to coordinate smoke control functions without damaging equipment. For example, the manual switches that control large central fan systems may also operate the mixing dampers to prevent tripping the high- and low-pressure cutouts.

Manual switches at the FSCS are either 2- or 3-position switches. Labels show the current state of each switch (Table 4).

**Table 4. Switch state descriptions**

Switch state	Equipment
ON-AUTO-OFF	Fans controlled by the smoke control system or other automatic control system
OPEN-AUTO-CLOSE	Dampers controlled by the smoke control system or other automatic control system
ON-OFF	Fans only controlled from the FSCS
OPEN-CLOSE	Dampers only controlled from the FSCS

### Smoke control system equipment

The smoke control system receives alarm signals from the FACP and manual command signals from the FSCS. On receiving alarm signals and/or manual commands, the smoke control system controls the mechanical smoke control equipment. Manual command signals from the FSCS take priority over alarm signals.



## Chapter 2 Pre-installation considerations

The smoke control system controls fans and positions dedicated and nondedicated dampers, both in the smoke control zones and at the air-handling systems. It may also position dampers or air modulation devices such as variable-air-volume (VAV) boxes serving the smoke control zones. Equipment associated with the smoke control system includes: dampers, fans, verification of operation equipment, and the Tracer™ MP581 programmable controller.

For VAV-based systems, there must be some form of duct pressure relief on each floor or in each smoke control zone. In smoke control mode, all return and supply dampers will be set to 100% open. If the VAV dampers are closed when this occurs, the duct pressure may be enough to damage duct work. To avoid this possibility, duct pressure relief dampers, either DDC or mechanically controlled, should be installed in the ductwork for each smoke control zone.

It should be noted that careful sizing of smoke control supply air damper and relief damper is necessary to use smoke purge and protect dampers.

In contrast to a VAV system, it is not necessary to provide separate duct pressure relief in constant volume as this is a form of dedicated smoke purge with supply and return/exhaust dampers already open. Supply dampers should be sized such that any one damper can spill an adequate amount of air.

### **Outdoor air, return air, relief, and exhaust dampers**

A nondedicated comfort control system controls outdoor air, return air, relief, and exhaust dampers. In normal operation, the return damper operates in opposition to the outdoor air damper. However, during smoke control system activation, all three dampers may be closed simultaneously to isolate the air-handling system for smoke control operations.

An elevator shaft damper, located at the top of a hoistway, relieves pressure generated during elevator operation. Since elevator shaft dampers are usually open, the natural stack effect of the building will tend to distribute smoke through the building via the elevator shafts. Some codes require a key-operated switch at the main floor lobby to close the elevator shaft damper. With local approval, this switch can be located at the FSCS.

### **Smoke dampers**

A smoke damper is located in any duct that penetrates a smoke zone perimeter. Smoke dampers that are listed by Underwriters Laboratories (UL) are subject to more stringent leakage tests than are standard control dampers. The listing usually includes the control actuator as part of the smoke damper assembly, but does not include the end switches.

### **IMPORTANT**

**Smoke dampers must have a Underwriters Laboratories (UL) listing for smoke control applications (UL 555S).**

Smoke dampers are ordered as a complete assembly. They are typically two-position dampers and have end switches that indicate the fully open and fully closed position. The switches are installed in the field. Dampers actuate with two types of control: pneumatic actuation and electrical actuation.

---

**Note:**

Switches that are part of the actuator do not provide an acceptable indication of actual damper travel. They only show the operation of the actuator and not the actual position of the damper.

For pneumatically actuated smoke dampers, the operating pressure range (spring range) and the normal position of the damper must be specified. Typically, the normal position will be closed (normally closed). The spring range must be high (8–13 lbs) to give the most close-off force.

Uniform Building Code 905.10.2 requires hard drawn, type L, copper pneumatic piping for smoke control system components. The air source must have automatic isolation valves separating it from pneumatic control devices not used for smoke control. Since the smoke control system will open and close smoke dampers, it may require an air pressure monitoring switch. If air pressure is lost in the smoke damper control lines, the switch transmits a Trouble indication.

For electrically actuated smoke dampers, the operating voltages are 24 Vac and 120 Vac. It is usually not possible to get actuators with DC operating voltages. A spring on the actuator positions the damper if power is lost. The power-loss position is typically the actuator closed (normally closed) position.

The electrical power that operates the smoke damper must be from an emergency power source and is monitored at a point after the last disconnect. The loss of electrical power initiates a Trouble indication.

**Fans**

Fans need additional control components for smoke control operation. Supply/return fan systems require independent control of fans. Multiple fan system Start and Stop points bypass some safety devices.

VAV systems require the smoke control system to be capable of either commanding the fans to full capacity or a higher capacity than comfort controls would command. High-pressure safeties are not bypassed in smoke control operation. Care must be taken to ensure that increased capacities do not trip high-pressure cutout devices. Excess pressures could deactivate fan systems, making them unusable for smoke control.

**Verification of operation equipment**

Codes require that the smoke control system provide verification of operation status indications at the FSCS. To accomplish this, the smoke control system provides devices that monitor the actual operation of fans

and dampers: status switches, differential pressure switches, airflow paddle switches, current-sensing relays, limit switches, and end switches.

Status switches at fans and dampers monitor the operation of the devices. Multiple binary inputs at the Tracer MP581s verify the On and Off status of fans and the Open and Closed status of dampers. If a status switch does not confirm the commanded (automatic or manual) operation, a Fail indicator activates at the FSCS. Failure detection must incorporate a time delay to give the devices time to function.

Differential pressure switches, airflow paddle switches, and current-sensing relays monitor fan operations. Differential switches piped across fan and paddle switches in the air stream can give erroneous indications.

### **IMPORTANT**

**A current-sensing relay is the preferred way to confirm the operating status of a fan.**

Limit switches and end switches monitor dampers. The switches activate damper Open and Closed signals for the FSCS. The damper blades activate the switches. Some codes require two switches in order to sense both the fully opened and fully closed position of the damper.

### **Tracer MP581 programmable controller**

The Tracer MP581 must have multiple binary inputs to verify the On and Off operation of fans. It must also have multiple binary inputs to verify the Open and Closed positions of dampers.

## **Equipment supervision**

Equipment supervision is a pre-installation consideration. Smoke control equipment must be supervised to ensure it is operational. Supervision techniques consist of confirming communications among system control panels, confirming operation in normal use situations, and performing weekly self-tests.

Confirming communications among all system control panels is a supervision technique that monitors basic system integrity. If any panel loses its communications, a Trouble alert is sent to the FSCS.

Normal use operations confirm the integrity of field point wiring for nondedicated equipment. Nondedicated equipment provides conditioned air to the building daily. When nondedicated equipment is not operational, comfort conditions deteriorate and building tenants notify maintenance personnel.

## System testing

System testing is a pre-installation consideration. To verify proper operation, the smoke control system must include provisions for: automatic weekly self-testing and manual periodic testing.

### Automatic weekly self-testing

As UL requires, the smoke control system provides automated weekly self-tests for dedicated smoke control system components. The self-tests activate components and monitor operation. They provide verification of operation status indications to the FSCS that show if the component passed or failed the test. Automatic weekly self-tests do not function if a smoke or fire alarm is present.

### Manual periodic testing

As NFPA 92A (NFPA 2000, *Recommended Practice for Smoke Control Systems*), chapter 5.4 requires, the smoke control system provides a manual testing capability. It provides annual tests for nondedicated system components and semi-annual tests for dedicated system components. The semi-annual tests are required in addition to the automated weekly self-tests for dedicated smoke control system components. Building maintenance personnel schedule and conduct the tests.

The manual periodic tests verify smoke control system responses to alarm zone inputs. Some of the manual testing must be performed with the system operating on emergency power, if applicable. An alarm must be generated in each zone. The system and equipment responses must be verified and recorded. Manual periodic testing should occur when the building is not occupied.

## Alarm response

Alarm response is a pre-installation consideration. NFPA 92A (NFPA 1996, *Recommended Practice for Smoke Control Systems*), section 3.4.5.5 requires the automatic response to an alarm to be based on the location of the first alarm. Subsequent alarms from other zones must be ignored for the purposes of automatic response.

## Automatic smoke control matrix

An automatic smoke control matrix (Table 5 on page 28, dedicated; Table 6 on page 28, nondedicated) shows each piece of mechanical equipment and each building zone. The matrix shows the automatic response of each piece of equipment to an initial alarm for each smoke zone. It also shows the mode of each zone based on an alarm in another zone. Commands from the FSCS may override the automatic responses. The matrix must be engineered for a specific project.

**Table 5. Sample automatic smoke control matrix (dedicated)**

Equipment	First smoke zone in alarm			
	Zone 1	Zone 2	Zone 3	Zone 4
Main sup fan	On	On	On	On
Main R/E fan	On	On	On	On
Stair press fan	On	On	On	On
1st flr sup dmpr	Close	Open	Close	Close
1st flr ret dmpr	Open	Close	Close	Close
2nd flr sup dmpr	Open	Close	Open	Close
2nd flr ret dmpr	Close	Open	Close	Close
3rd flr sup dmpr	Close	Open	Close	Open
3rd flr ret dmpr	Close	Close	Open	Close
4th flr sup dmpr	Close	Close	Open	Close
4th flr ret dmpr	Close	Close	Close	Open
Smoke zone 1	Alarm	Adjacent	Unaffected	Unaffected
Smoke zone 2	Adjacent	Alarm	Adjacent	Unaffected
Smoke zone 3	Unaffected	Adjacent	Alarm	Adjacent
Smoke zone 4	Unaffected	Unaffected	Adjacent	Alarm

**Table 6. Sample automatic smoke control matrix (nondedicated)**

Equipment	First smoke zone in alarm			
	Zone 1	Zone 2	Zone 3	Zone 4
Main sup fan	On	On	On	On
Main R/E fan	On	On	On	On
Stair press fan	On	On	On	On
1st flr sup dmpr	Open	Open	Open	Open
1st flr ret dmpr	Open	Open	Open	Open
2nd flr sup dmpr	Open	Open	Open	Open
2nd flr ret dmpr	Open	Open	Open	Open
3rd flr sup dmpr	Open	Open	Open	Open
3rd flr ret dmpr	Open	Open	Open	Open
4th flr sup dmpr	Open	Open	Open	Open
4th flr ret dmpr	Open	Open	Open	Open
Smoke zone 1	Alarm	Adjacent	Open	Open
Smoke zone 2	Adjacent	Alarm	Adjacent	Open
Smoke zone 3	Open	Adjacent	Alarm	Adjacent
Smoke zone 4	Open	Open	Adjacent	Alarm



## Response times

Response times are a pre-installation consideration. For a discussion of response time requirements for smoke control systems, refer to NFPA 92A (NFPA 2000, *Recommended Practice for Smoke Control Systems*), section 3.4.3.3 and NFPA 92B (NFPA 2000, *Guide for Smoke Management Systems in Malls, Atria, and Large Areas*), section 4.4.4. The activation sequence should be accomplished so as to avoid damage to the equipment. For example, the dampers should be opened before starting the fans. Table 7 shows the required response times, as published in the referenced NFPA documentation.

**Table 7. NFPA response time requirements**

Component	Response time
Damper operation to desired state (open or closed)	75 seconds
Fan operation to desired state (on or off)	60 seconds

**Note:**

Some building codes such as the Uniform Building Code have much more stringent response times. As with all of the considerations discussed in this chapter, the local authority having jurisdiction (AHJ) has the final word.

## Cable distance considerations

Table 8 on page 30 given cabling distance requirements for data of two different types:

- Hardware based, such as from analog or binary inputs and outputs
- Communication based, such as from the LonTalk communication link or I/O bus (EX2)

The table also presents different cabling distance requirements depending on whether the data path is monitored or unmonitored.

There are no stated distance limitations for monitored information paths. The maximum distance allowed is the same as the manufacturer's stated maximum distance for that particular data type. A data path is considered monitored if some notification for opens, ground-shorts, and conductor shorts is available and used (NFPA 72A [2002] section 4.4.7.1).

**Note:**

Process verification, sometimes referred to as *end-to-end testing*, can be considered a means of monitoring data (NFPA 92A [2000] section 3.4.6). Communicated values are an example of process verification. A communication link can be monitored for quality, and the system can be notified if there is a communications failure.

Distance limitations for unmonitored data paths are severely limited.

**Table 8. Cabling practices and restraints**

Maximum distance	Type
<b>Monitored data paths</b>	
Refer to the best wiring practices given in BMTX-SVN01A-EN for installing Lontalk communication links.	Trane LonTalk communication link
Refer to the wiring requirements given in CNT-SVN01C-EN for the I/O bus wiring between the Tracer MP580/581 and the EX2s.	Tracer MP580/581 EX2 I/O bus communication link
<b>Unmonitored data paths</b>	
3 ft (1 m) (NFPA 72A [2002] section 6.15.2.2)	Unmonitored distance from pilot relay or controller output to actuator
20 ft (6 m) <i>and</i> in conduit (NFPA 72A [2002] section 4.4.7.1.8)	FACP to Tracer MP581/EX2 interface wiring FSCS to Tracer MP581/EX2 interface wiring
<b>Note:</b> Questions regarding this information given in this table should be directed to the authority having jurisdiction (AHJ), if possible.	



## Chapter 3

# Installation diagrams

---

## Smoke control system overview

An engineered smoke control system can be added on to a Tracer Summit™ building automation system. The system layout, wiring requirements, and capacities for smoke control applications differ from Tracer Summit systems that do not employ smoke control.

A smoke control installation includes a Trane building control unit (BCU), the Tracer MP581 programmable controller, and wiring. These devices should be wired on the smoke control communication link. Devices that are a part of the Tracer Summit system, but are not used by the smoke control system, must be on a separate communication link.

### **IMPORTANT**

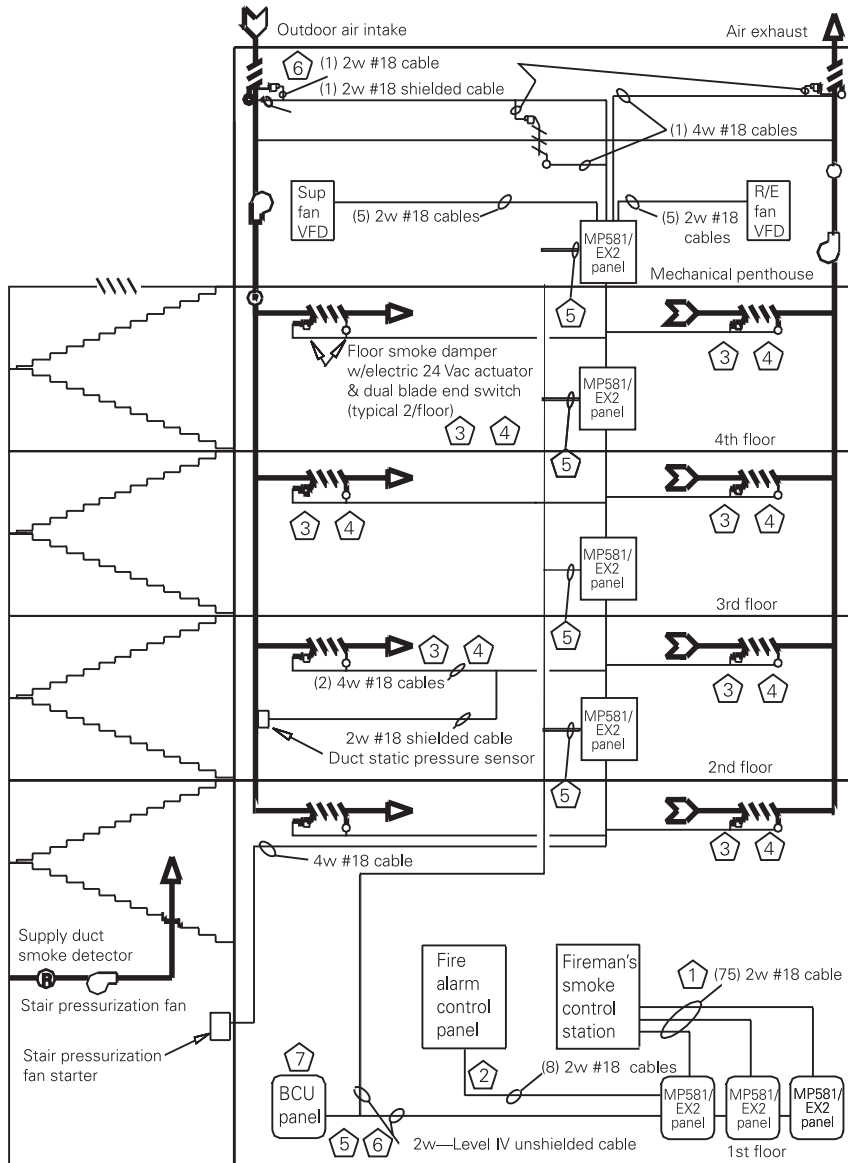
**For dedicated smoke control system, only Tracer MP581s used for smoke control are allowed on the LonTalk communication link. Tracer MP581s and other LonTalk UCMS not involved in smoke control *must* be connected to other BCUs. A nondedicated smoke control system can have other LonTalk devices connected to the communication link.**

Installation diagrams consist of system riser and system termination diagrams. These diagrams provide requirements and restrictions to the installer.

## System riser diagrams

System riser diagrams (Figure 11) show panel locations, power requirements, power sources, and interconnecting wiring requirements. They also show the wiring that must be in conduit.

**Figure 11. Sample system riser diagram**



NOTES: Wiring indicated is for sample project only. Refer to Tracer MP581 and BCU installation guides for specific wire type and distance requirements. BCUs and Tracer MP581s used for smoke control have the same minimum requirements as those used for standard HVAC control.

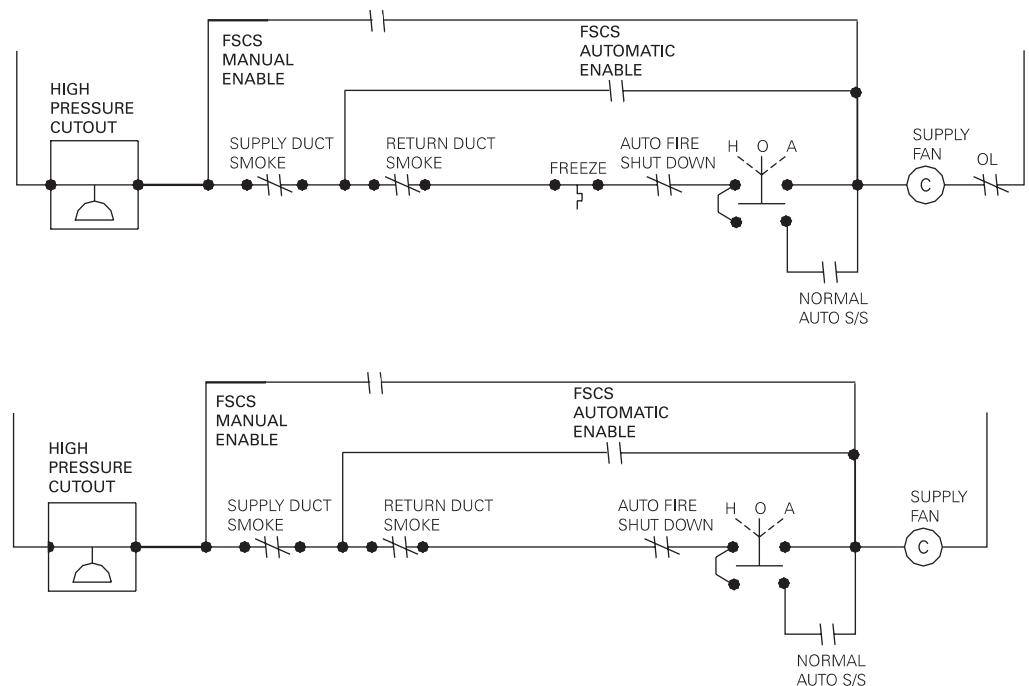
- 1 Wiring between Tracer MP581 and FSCS must be in conduit and in the same room. Not to exceed 20 ft (6.1 m) in length.
- 2 Wiring between Tracer MP581 and FACP must be in conduit and in the same room. Not to exceed 20 ft (6.1 m) in length.
- 3 Electrical power for damper actuator must be monitored after last disconnect.
- 4 Damper blade end switch is dual switch indicating fully open AND full closed positions.
- 5 For dedicated smoke control systems, only Tracer MP581s used for smoke control are allowed on the LonTalk communication link. Tracer MP581s and other LonTalk UCMS not involved in smoke control *must* be connected to other BCUs. A nondedicated smoke control system can have other LonTalk devices connected to the communication link.
- 6 Modulating outdoor, return, and exhaust damper actuators require shielded cable from analog output.
- 7 Wiring between BMTX BCU and BMTX BCU using an Ethernet LAN must be in conduit, located in the same room, and not to exceed 20 ft.

## System termination diagrams

System termination diagrams show wire terminations at panels and field devices. Guidelines for creating system termination diagrams include:

- Diagrams for Tracer MP581 panels may be formatted as lists.
- Diagrams for field devices show: normal state, expected operation, and voltage requirements. An example of a normal state notation is *normally open*. An example of an expected operation description is *closed contact opens damper*.
- Diagrams for field devices not furnished by Trane are created during installation. After installation, the diagrams become part of the as-built documentation.
- Diagrams for the control of starters and variable flow devices (VFDs) must show the required relays and connections for the hierarchy of control (Figure 12 on page 33). Relays must enable starters and VFDs to bypass some safety devices and the local manual switches. Also, manual controls from the firefighter's smoke control station (FSCS) must be wired to give them the highest priority of control.

**Figure 12. Sample fan starter wiring diagram**

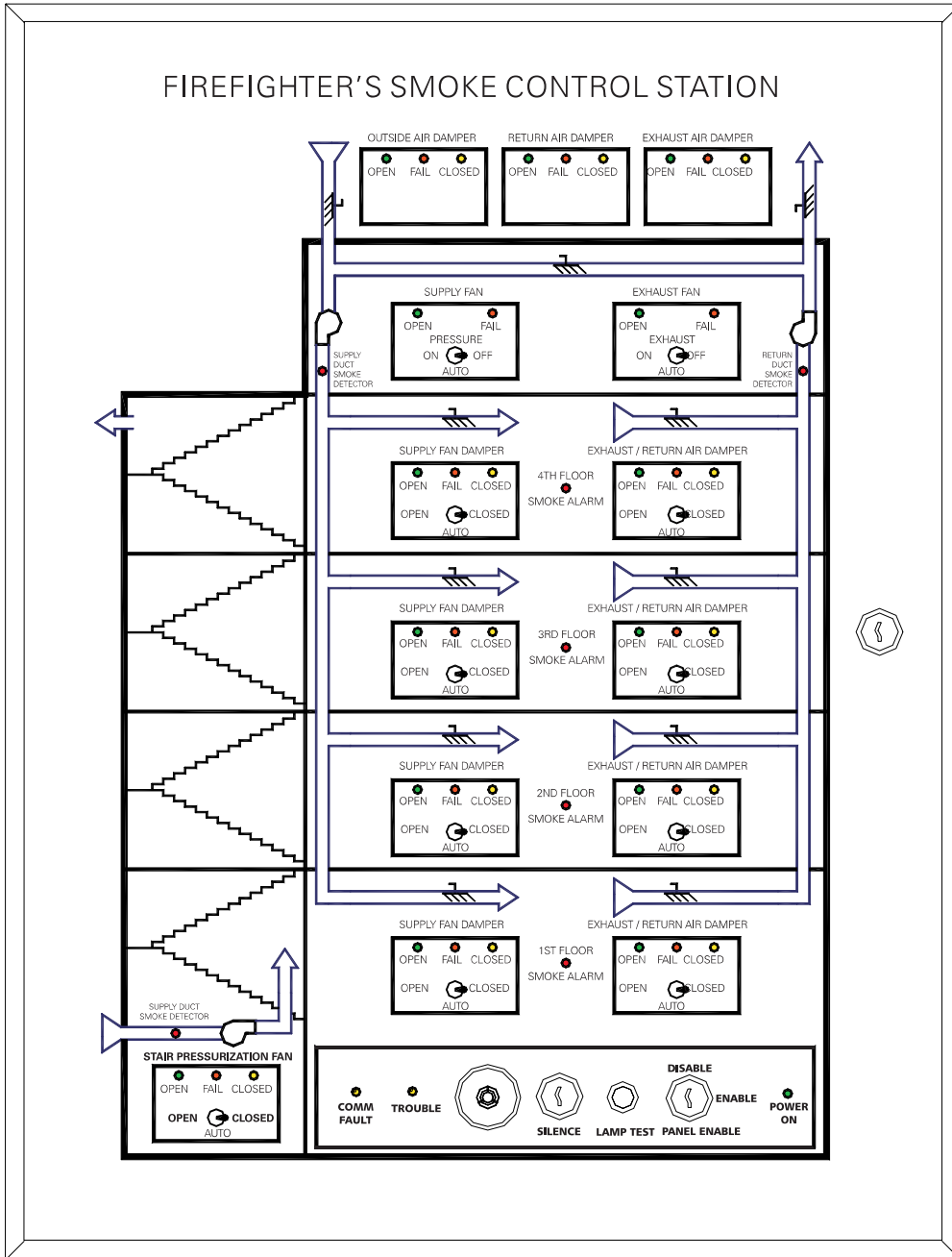


Note: Pressure cutouts, duct smoke detectors and auto shutdown are two-pole.

### Tracer MP581 to FSCS wiring

The FSCS panel is designed for a specific smoke control system (Figure 13). The FSCS panel comes from a listed vendor and is provided as part of the smoke control system. Before ordering the panel, UL must approve front panel drawings that show lights and switches.

Figure 13. Sample FSCS panel



The wiring between a Tracer MP581 and the FSCS is non-supervised and power limited. Additional requirements are:

- Tracer MP581 and FSCS must be in the same room.
- Wiring between the Tracer MP581 and FSCS must be in conduit.
- Wiring distance cannot exceed 20 ft.
- Wire must be #18 AWG.

The number of wires needed between the Tracer MP581(s) and the FSCS is determined by the total number of zones and manual override switches at the FSCS. Multiple Tracer MP581 panels may be required to monitor and control the FSCS. One Tracer MP581 controls the trouble LED and the Sonalert audible alarm of the FSCS, as well as supplying 24 Vac power to operate the lamp test relay(s).

Table 9 shows wires for a typical Tracer MP581 that controls the FSCS trouble LED and the Sonalert audible alarm.

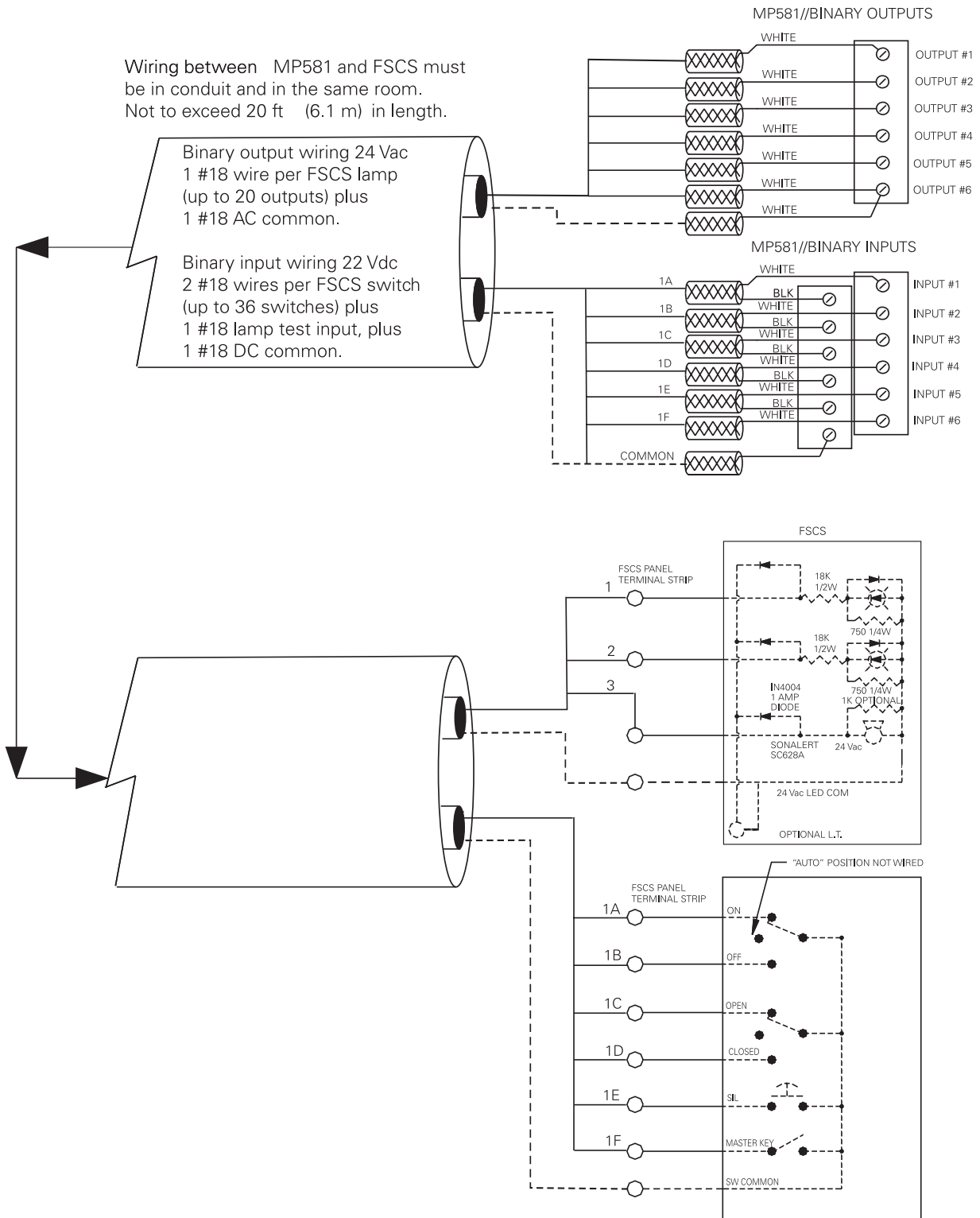
Figure 14 on page 36 shows Tracer MP581 to FSCS wiring.

**Table 9. Wires for a Tracer MP581 that control FSCS trouble LED and Sonalert alarm**

<b>Cables per Tracer MP581</b>	<b>Type of wiring</b>	<b>Function</b>
1–22	24 Vac	Binary output to light LED on FSCS
1	24 Vac	Binary output controlling trouble LED
1	24 Vac	Binary output controlling Sonalert alarm LED
1	24 Vac	Binary output controlling Sonalert alarm
1	24 Vac	“Hot” power wire for the FSCS lamp test relays
1	24 Vac	Common
1–36	22 Vdc	Two binary input wires per FSCS switch (up to 36 switches per Tracer MP581)
1	22 Vdc	Binary input wire for lamp test signal
1	22 Vdc	Common

Chapter 3 Installation diagrams

Figure 14. Tracer MP581 to FSCS wiring





### Tracer MP581 to FACP wiring

The wiring between the Tracer MP581 and the FACP is non-supervised and power limited. In addition:

- Tracer MP581 and FACP must be in the same room.
- Wiring between the Tracer MP581 and FACP must be in conduit.
- Wiring distance cannot exceed 20 ft.
- Wire must be #18 AWG.

The number of wires needed between the Tracer MP581(s) and the FACP is determined by the total number of zones in the fire alarm system. Multiple Tracer MP581 panels may be required to monitor and control the FACP.

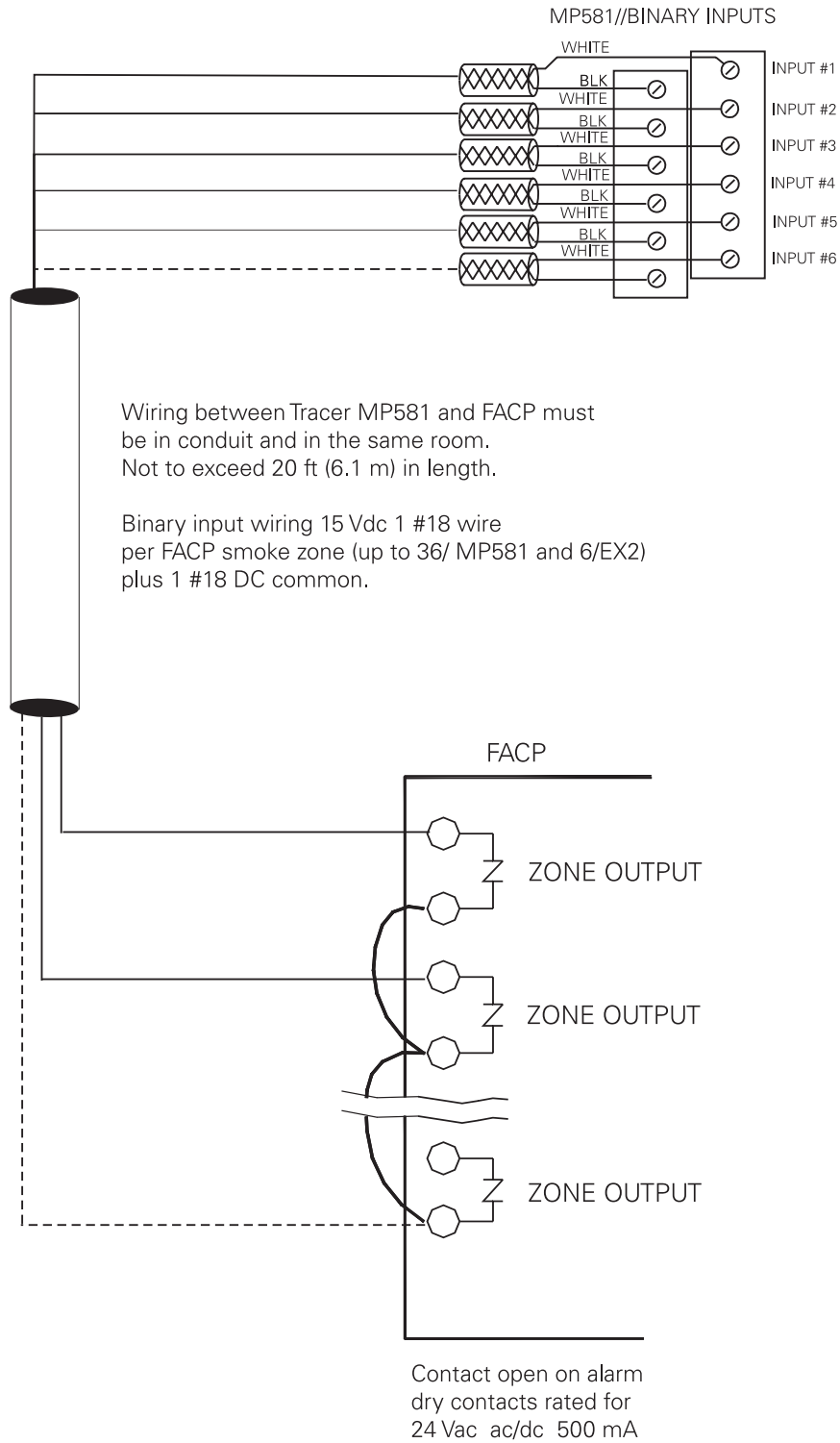
Table 10 gives wiring information for a typical Tracer MP581 that communicates to an FACP.

Figure 15 on page 38 shows the details for wiring a Tracer MP581 to an FACP.

**Table 10. Wiring for a typical Tracer MP581 that communicates to an FACP**

Cables per Tracer MP581	Type of wiring	Function
1–36	22 Vdc	Two binary input wires per FSCS switch (up to 36 per Tracer MP581)
1	22 Vdc	Common

Figure 15. Tracer MP581 to FACP wiring



## Chapter 4

# Installing the Tracer Summit BMTX BCU

---

## Mounting the hardware

Make sure that the selected location meets the operating environment requirements described in this section and clearance requirements described in this Figure 16 on page 40. The BCU must be installed indoors. Trane recommends locating it:

- Near the controlled equipment to reduce wiring costs
- Where service personnel have easy access
- Where it is easy to see and to interact with the operator display
- Where public access is restricted to minimize the possibility of tampering or vandalism

### CAUTION

#### Avoid equipment damage!

Install the BCU in a location that is out of direct sunlight. Failure to do so may cause it to overheat.

## Operating environment requirements

Make sure that the operating environment conforms to the specifications listed in Table 11. Enclosure dimensions are illustrated in Figure 17 on page 41.

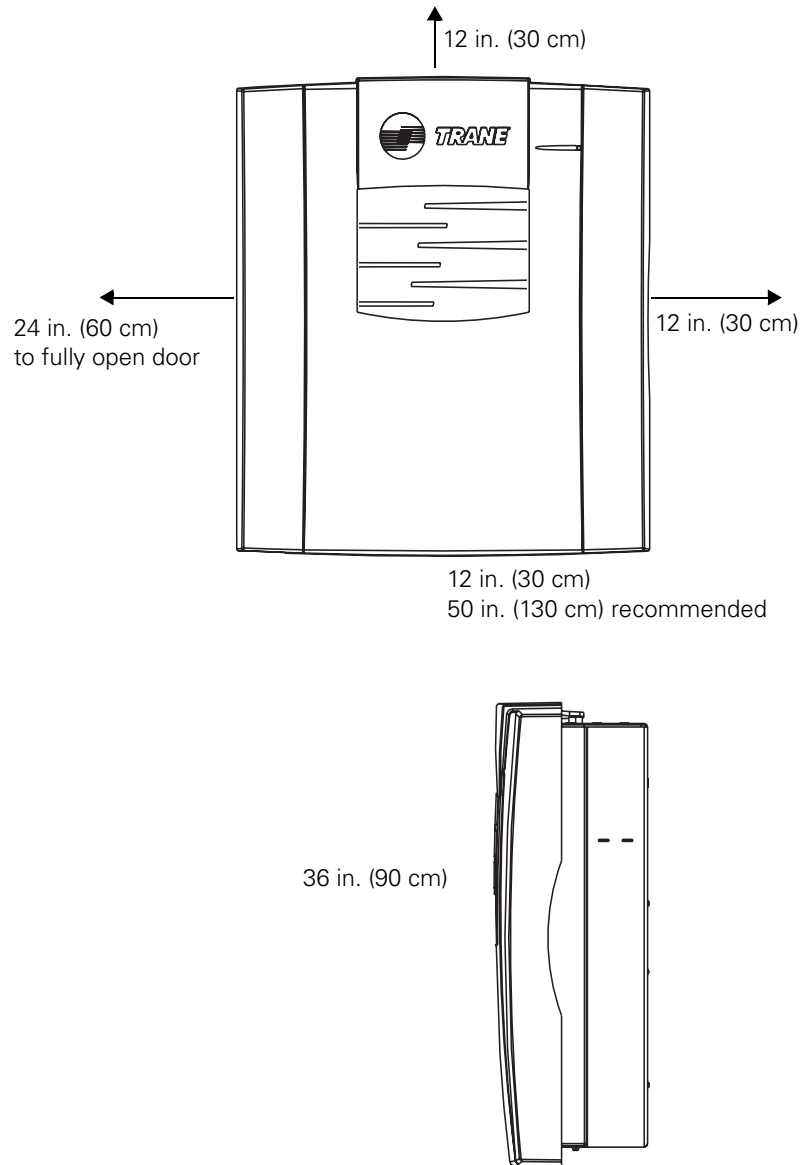
**Table 11. Operating environment specifications**

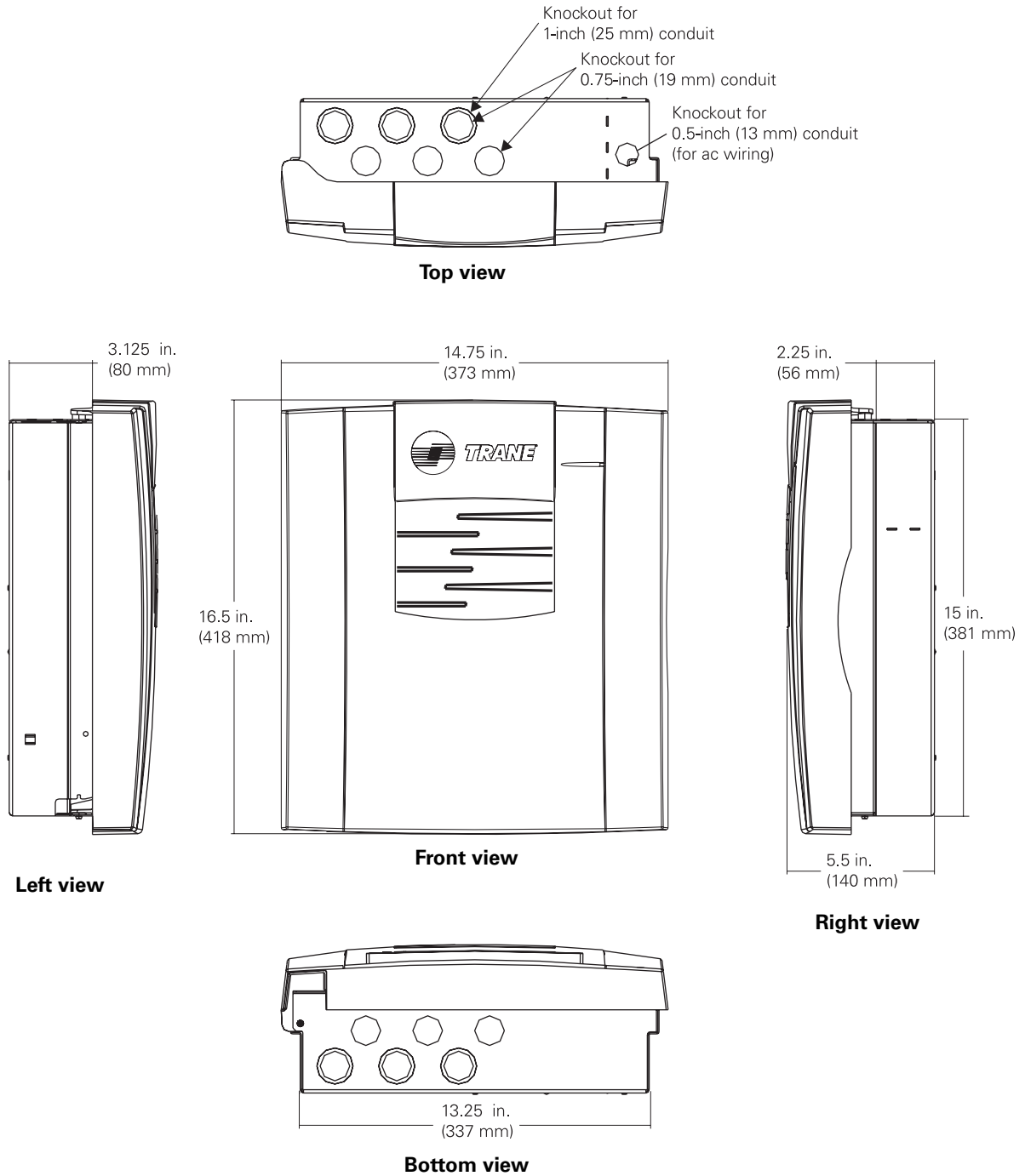
<b>Temperature</b>	From 32°F to 120°F (0°C to 49°C)
<b>Humidity</b>	10–90% non-condensing
<b>Power requirements</b>	North America: 120 Vac 1 A maximum, 1 phase, 50 or 60 Hz
<b>Weight</b>	Mounting surface must be able to support 60 lb (28 kg)
<b>Dimensions</b>	16 ½ in. × 14 ¾ in. × 5 ½ in. (418 mm × 373 mm × 140 mm)
<b>Altitude</b>	6500 ft (2000 m)
<b>Installation</b>	Category 3
<b>Pollution</b>	Degree 2

### Clearances

Make sure that the mounting location has enough room to meet the minimum clearances shown in Figure 16.

**Figure 16. Minimum clearances for the BMTX BCU enclosure**



**Figure 17. BMTX BCU enclosure dimensions**


**Note:** Six of the twelve knockouts are dual-sized knockouts for 1-inch (25 mm) and 0.75-inch (19 mm) conduit.

## Mounting the back of the enclosure

The back of the enclosure is shipped with the termination board installed inside it.

### IMPORTANT

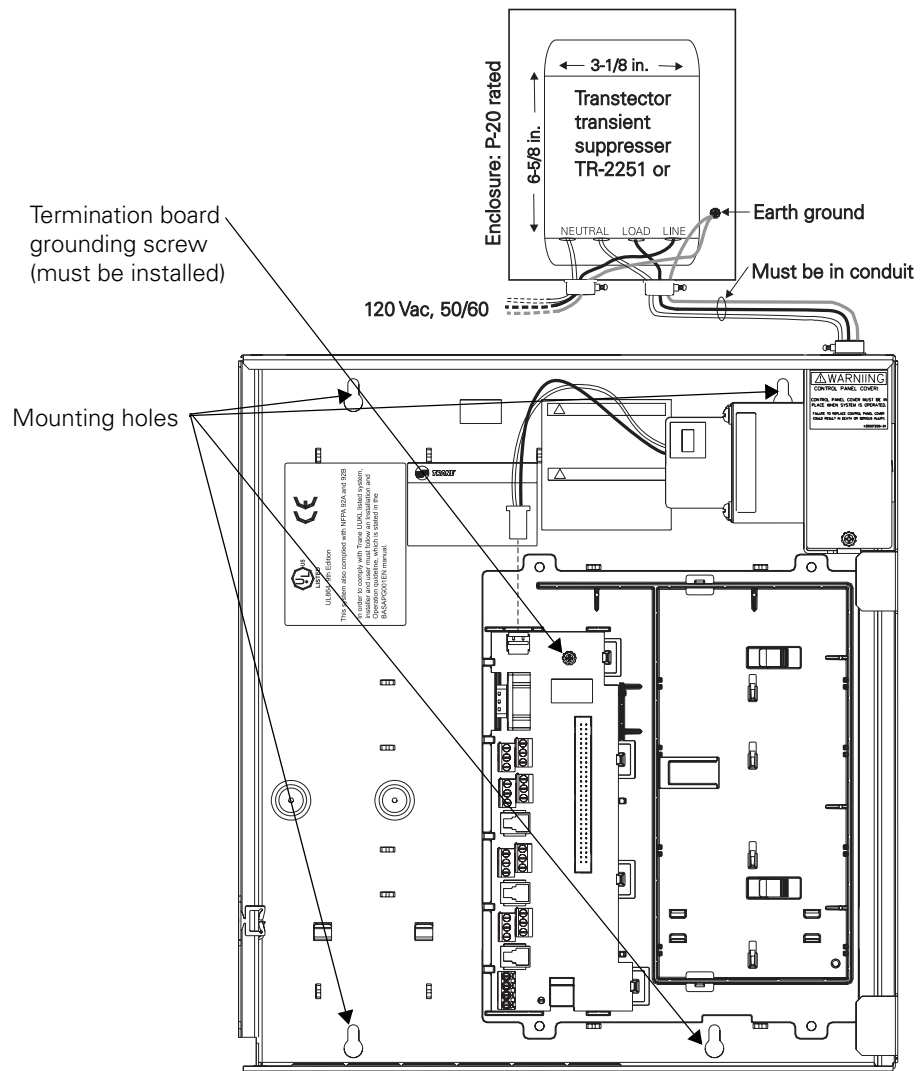
The termination board should be shipped with the grounding screw installed. Verify this by checking the location shown in Figure 18.

The enclosure door is shipped separately. If the door has already been attached to the enclosure back, remove it.

To mount the back of the enclosure:

1. Using the enclosure back as a template, mark the location of the four mounting holes on the mounting surface (see Figure 18).

**Figure 18. Enclosure mounting holes**



2. Set the enclosure back aside and drill holes for the screws at the marked locations.  
 Drill holes for #10 (5 mm) screws or #10 wall anchors. Use wall anchors if the mounting surface is dry wall or masonry.
3. Insert wall anchors if needed.
4. Secure the enclosure back to the mounting surface with the supplied #10 (5 mm) screws.

## Wiring high-voltage ac power

### Verifying model number for local power requirements

Table 12 lists the available BMTX BCU model. You can find the model number on the shipping label or on the product label inside the enclosure.

**Table 12. BMTX BCU model number**

Model	Description
BMTX001DAB000	BMTX BCU, 120 Vac, UUKL listed

To ensure proper operation of the BMTX BCU, install the power supply circuit in accordance with the following guidelines:

- The BCU must receive power from a dedicated power circuit. Failure to comply may cause control malfunctions.
- A disconnect switch for the dedicated power circuit must be near the controller, within easy reach of the operator, and marked as the disconnecting device for the controller.
- High-voltage power-wire conduits or wire bundles must not contain input/output wires. Failure to comply may cause the controller to malfunction due to electrical noise.
- High-voltage power wiring must comply with the National Electrical Code (NEC) and applicable local electrical codes.
- High-voltage wiring requires three-wire 120/230 Vac service (line, neutral, ground).

**Note:**

The transformer voltage utilization range is 120 Vac. The panel automatically detects whether the current is 50 or 60 cycle.

To connect high-voltage power wires:

### **WARNING**

#### **Hazardous voltage!**

**Before making electrical connections, lock open the supply-power disconnect switch. Failure to do so may cause death or serious injury.**

**CAUTION****Use copper conductors only!**

**Unit terminals are designed to accept copper conductors only. Other conductors may cause equipment damage.**

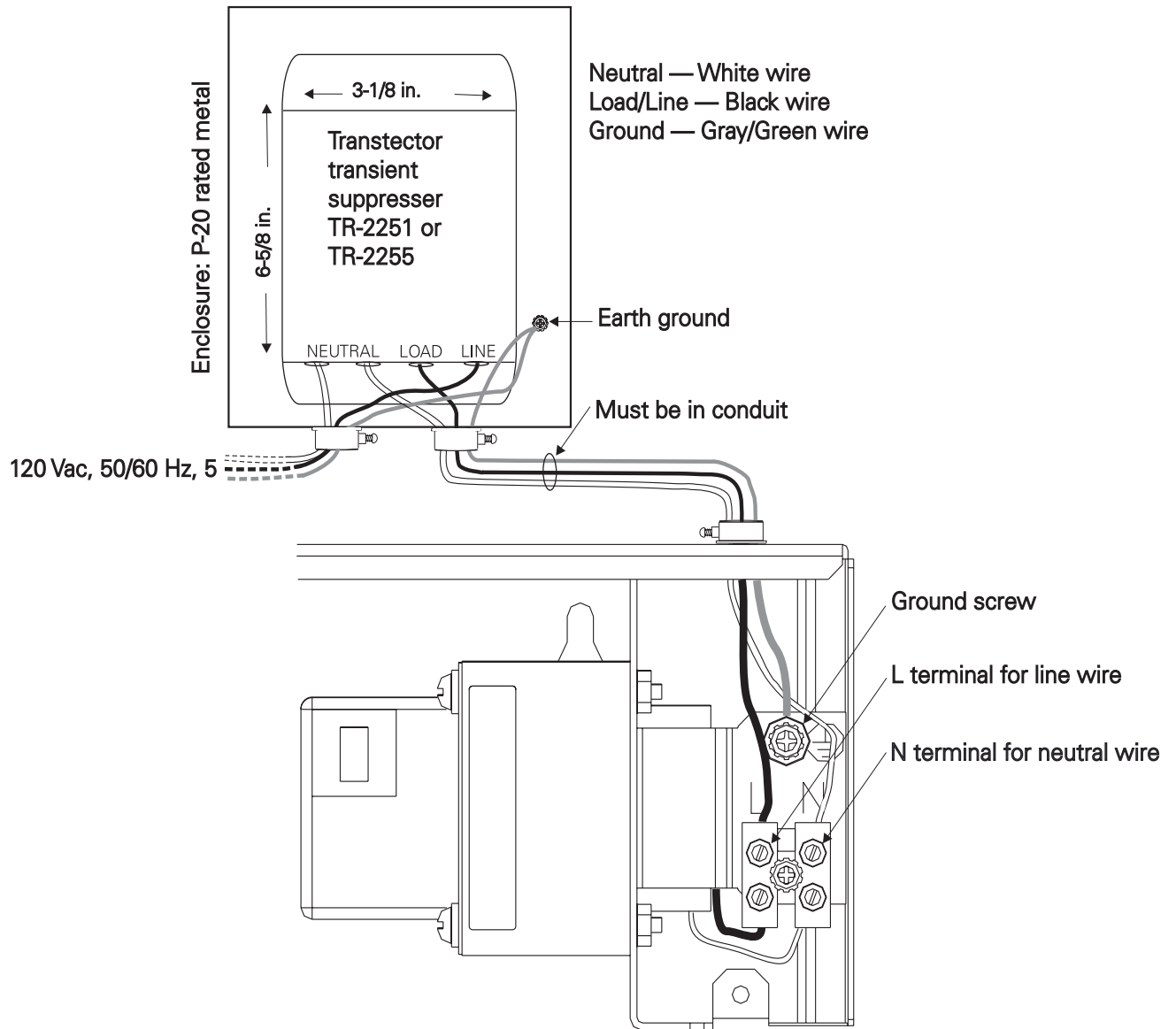
1. Lock open the supply-power disconnect switch.
2. At the top-right corner of the enclosure, remove the knockout for ½ in (13 mm) conduit.
3. Open or remove the enclosure door if it has already installed.
4. Inside of the enclosure at the top-right corner, remove the high-voltage area cover plate.
5. Feed the high-voltage power wire into the enclosure.
6. Connect the line wire to the L terminal as shown in Figure 19 on page 45.
7. Connect the neutral wire to the N terminal.
8. Connect the green ground wire to the chassis ground screw. The ground wire must be continuous back to the circuit breaker panel.
9. Replace the cover plate.

** WARNING****Hazardous voltage!**

**The cover plate must be in place when the BCU is operating. Failure to replace the cover plate could result in death or serious injury.**

10. On a label, record the location of the circuit breaker panel and the electrical circuit. Attach the label to the cover plate.



**Figure 19. AC wiring**


## EMI/RFI considerations

Take care to isolate HVAC controllers from electromagnetic interference (EMI) and radio frequency interference (RFI). Such interference can be caused by radio and TV towers, hospital diagnostic equipment, radar equipment, electric power transmission equipment, and so on. In addition, take care to prevent the BMTX BCU from radiating EMI and/or RFI.

The BMTX BCU is equipped with EMI/RFI filters that trap RFI to ground. In most situations, a good earth ground will reduce EMI/RFI problems by acting as a drain for EMI and RFI. If the BMTX BCU is receiving or radiating interference, make sure that the earth ground is good. Do not assume that the building conduit is an adequate ground.

### Checking the earth ground

Though a proper earth ground is especially important in areas of high EMI or RFI, always check the quality of the ground, regardless of location.

#### **⚠ WARNING**

#### **Hazardous voltage!**

**The cover plate must be in place when the BCU is operating. Failure to replace the cover plate could result in death or serious injury.**

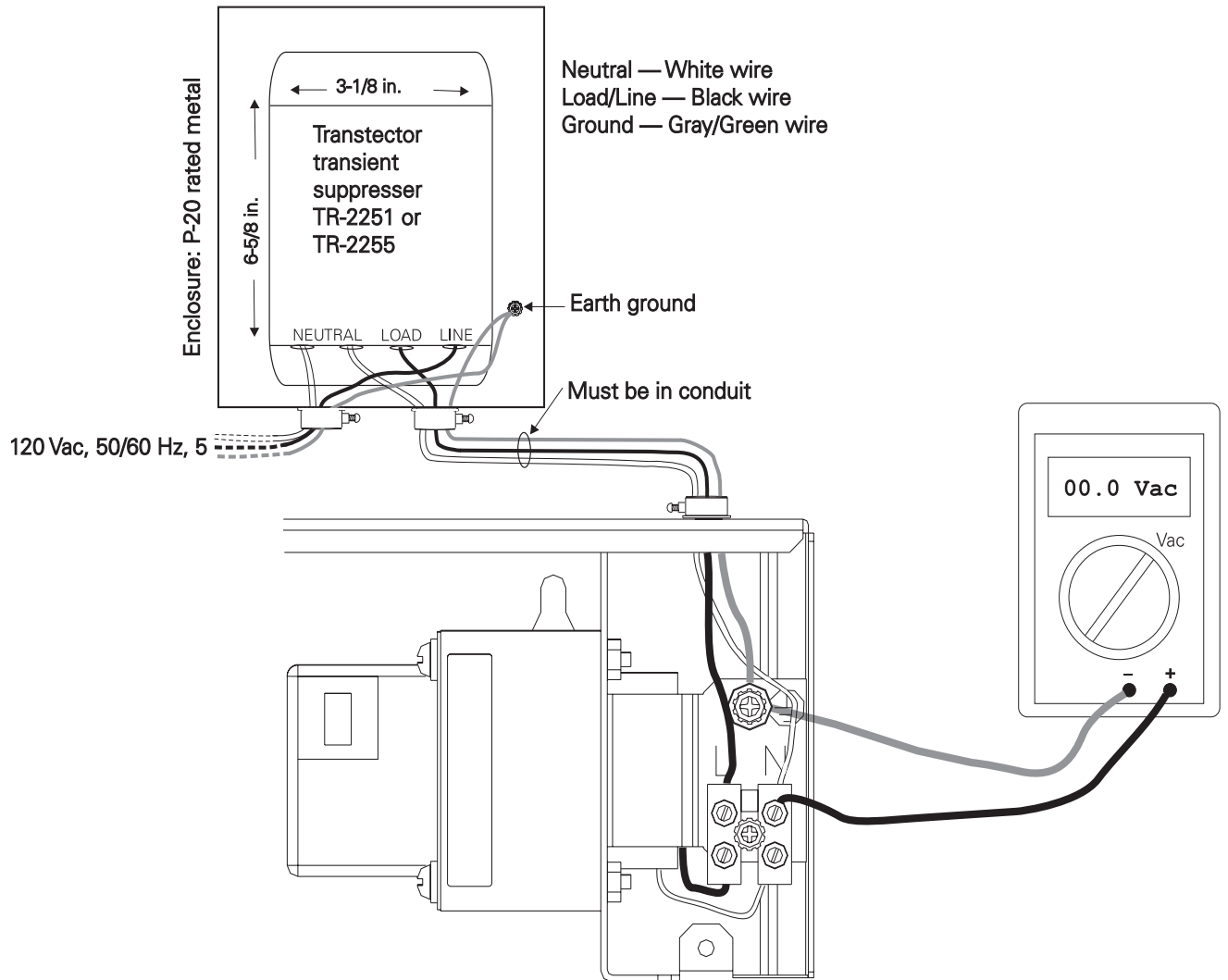
**If the earth ground has a voltage of more than 4 Vac, use a different ground. Failure to do so could result in death or serious injury.**

To check the quality of the earth ground:

1. Open the enclosure door.
2. Inside of the enclosure at the top-right corner, remove the high-voltage area cover plate.
3. Measure the ac voltage between the earth ground and the neutral terminal, as shown in Figure 20 on page 47.

Ideally, the voltage should be 0 Vac. Find a different ground if the voltage exceeds 4 Vac. A higher voltage may result in:

- Danger to people touching the enclosure
  - Erratic communications
  - Erratic equipment operation (Because noise may affect voltage levels at the inputs—the controller interprets input noise as changes in temperature, humidity, pressure, and so on.)
4. Replace the cover plate.

**Figure 20. Checking the earth ground**


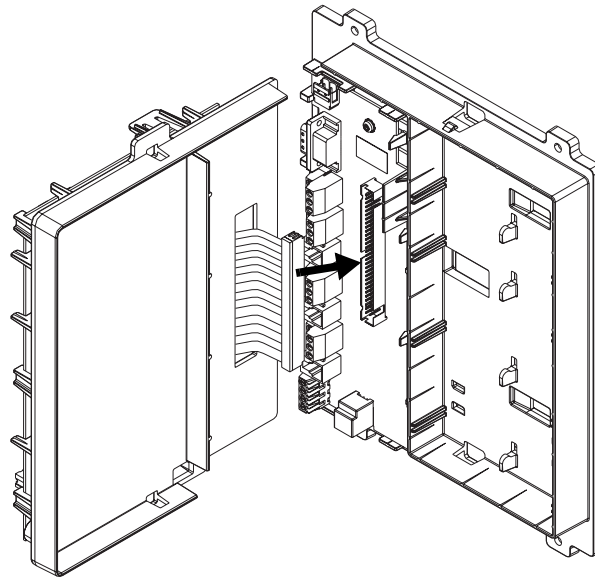
## Connecting the main circuit board

The main circuit board is attached to a plastic frame. It is shipped separately. The board can be kept in the office and programmed while the back of the enclosure is mounted and the termination board, which is attached to the back of the enclosure, is wired. After programming has been completed, connect the circuit board to the termination board as shown in the following procedure.

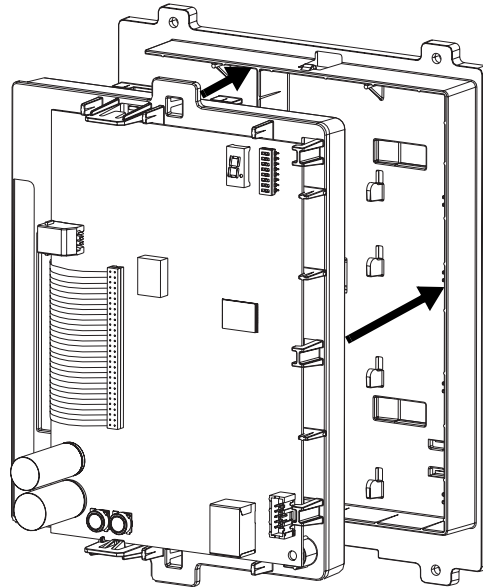
To connect the circuit board:

1. Verify that the 24 Vac power cable is not connected to the termination board.
2. Hold the circuit board frame at a 90° angle to the back of the enclosure, as shown in Figure 21.
3. Connect the circuit board's 60-pin ribbon cable to the termination board's 60-pin slot. The connector is keyed to the slot. To avoid difficulty, make sure that the key is lined up with the slot.

**Figure 21. Connecting the circuit board ribbon cable**



1. Align the snaps on the circuit board frame with the mounting locks at opposite ends of the enclosure back, as shown in Figure 22 on page 49.
2. Using the tabs that are at both ends of the top frame, push the two frames together. You will hear a click when the frames connect.

**Figure 22. Connecting the frames**

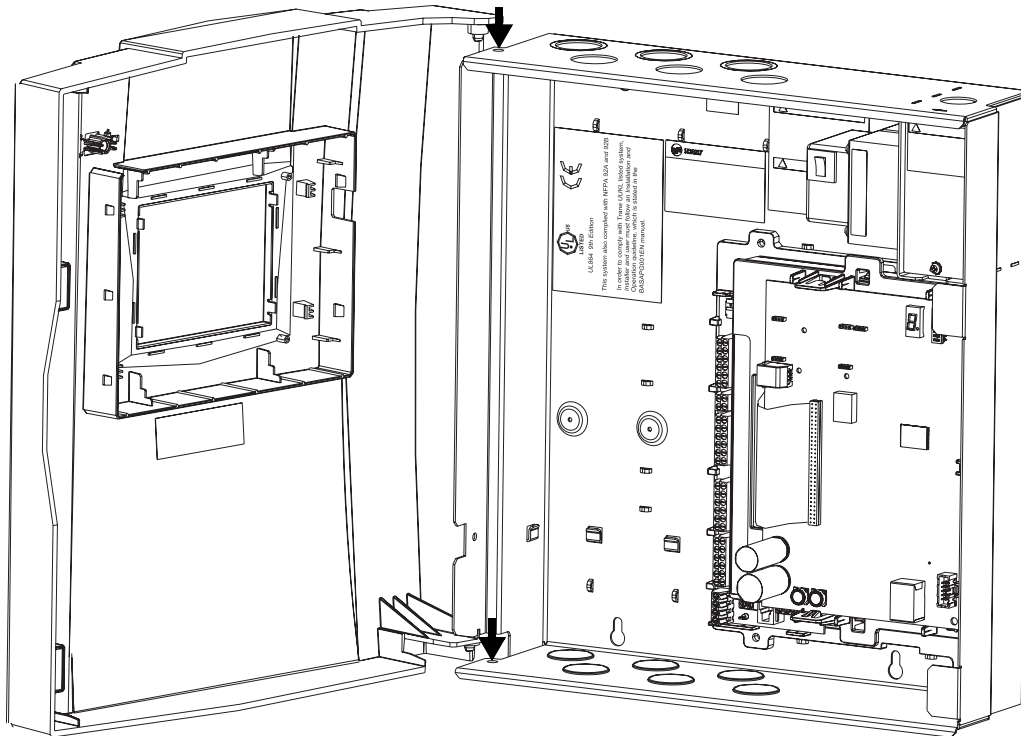
3. Connect the 24 Vac power cable to the termination board. The seven-segment LED display should light up.
4. Connect the Ethernet cable to the Ethernet connector on the circuit board (this step applies to UUKL nondedicated systems only).

## Installing the door

To install the enclosure door:

1. Unpack the door and check for missing or damaged parts.  
Check to make sure that the magnetic latches are installed. Check for any cracks in the plastic.
2. Hold the door at a 90° angle from the enclosure back as shown in Figure 23.
3. Align the hinge pegs on the door with the hinge holes on the enclosure.
4. Gently lower the door until it rests securely in the hinge holes.
5. Verify that the door swings freely on the hinges and that the magnetic latches hold the door securely when it is closed.

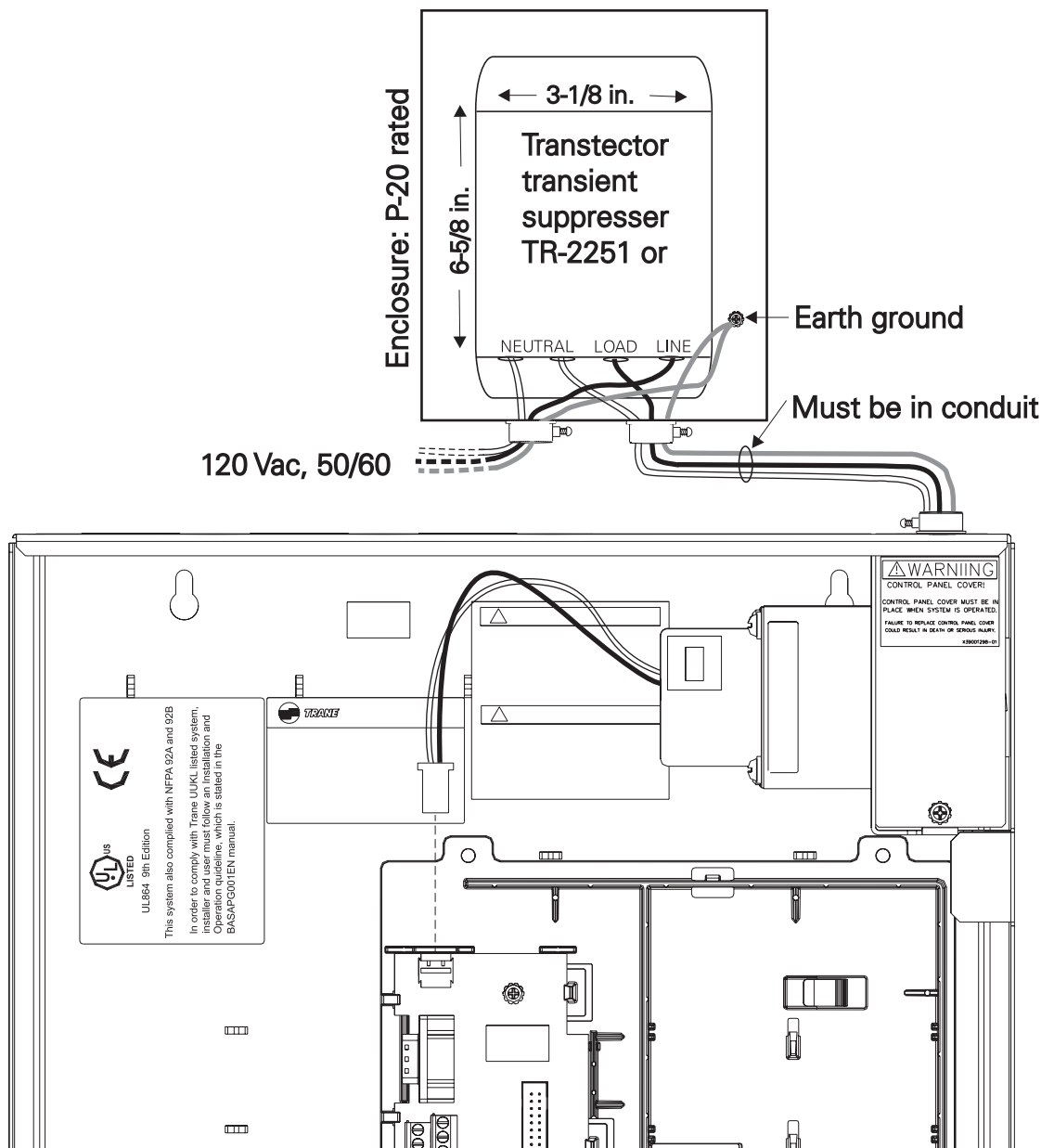
**Figure 23. Installing the door**



## Transtector, Ethernet (UUKL nondedicated only), and LonTalk connections on the BMTX BCU

To comply with UUKL, a protection device must be wired to the BMTX BCU to reduce transients in the ac power. Figure 24 describes connecting an ac power transient protection device to a BMTX BCU.

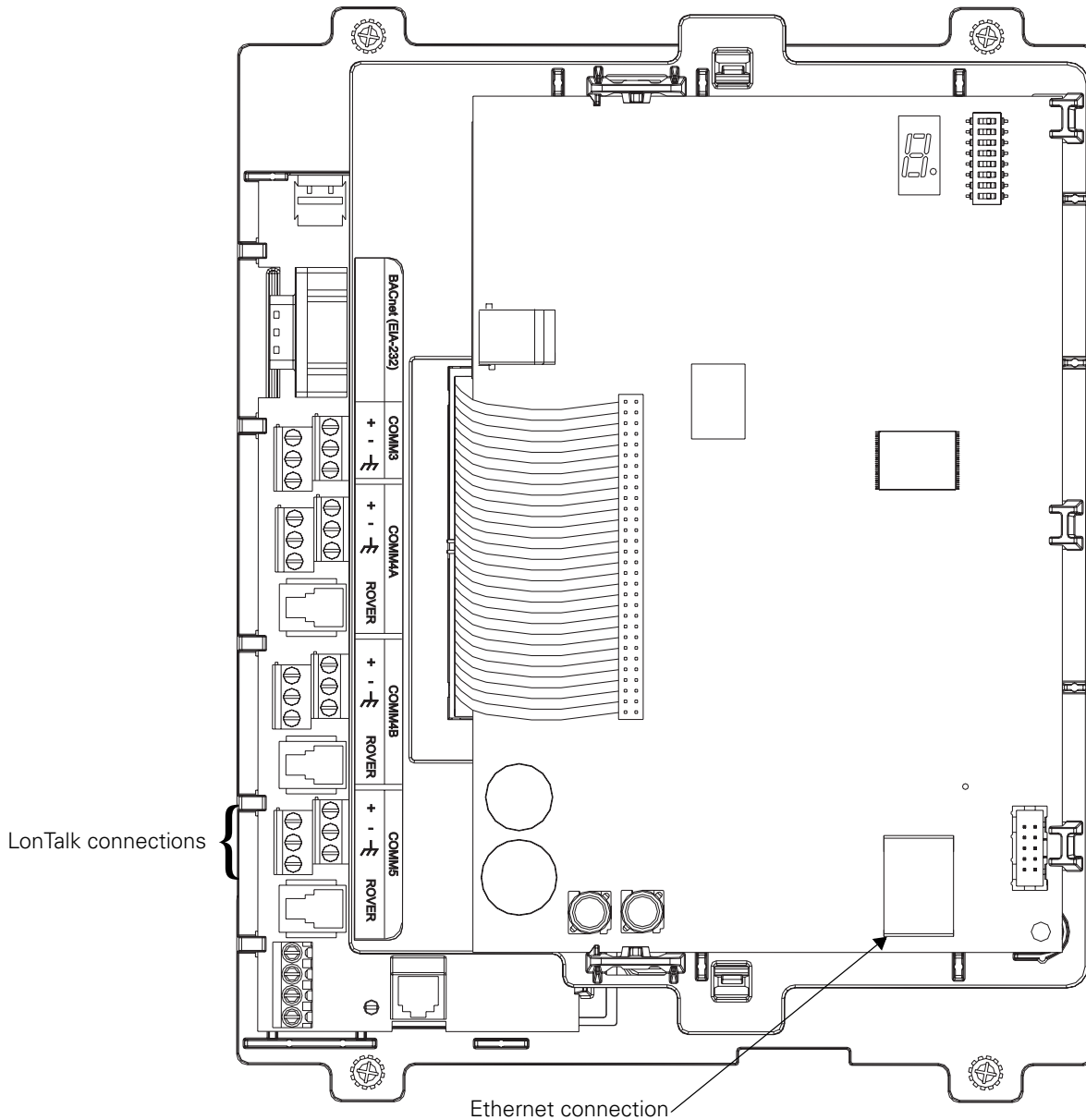
**Figure 24. AC power transient protection wiring to the BMTX BCU**



## Chapter 4 Installing the Tracer Summit BMTX BCU

Figure 25 shows the Ethernet LAN connection (UUKL nondedicated only) and the LonTalk connection to the BMTX BCU.

**Figure 25. Ethernet (UUKL nondedicated only) and LonTalk connection locations on the BMTX BCU**



**Note:**

A fully configured BCU draws a maximum of 25 VA from the power transformer. No other devices may be powered from the transformer.



## Chapter 5

# Installing the Tracer MP581 programmable controller

---

## Installation guidelines

Guidelines for installing a Tracer MP581 include:

- A Tracer MP581 that monitors the fire alarm control panel for consistency (FACP) must be installed in the same room as the FACP. It must be installed within 20 feet of the FACP. Cables between the FACP and the Tracer MP581 must be in conduit.
- A Tracer MP581 that monitors and controls the fire smoke control system (FSCS) must be installed in the same room as the FSCS. It must be installed within 20 feet of the FSCS. Cables between the FACP and Tracer MP581 must be in conduit.

### ▲IMPORTANT

**Wiring between the Tracer MP581 and the FACP and between the Tracer MP581 and the FSCS (point wiring) must be in conduit. The conduit requirement is necessary, since the binary inputs to the Tracer MP581 are not supervised.**

- Wiring from a Tracer MP581 to field sensors and relays is not supervised. Installation of this wiring must conform to more stringent requirements when a Tracer MP581 is part of a smoke control system than when it is part of a standard mechanical system control.

## Specifications

The Tracer MP581 conforms to the specifications shown in Table 13.

**Table 13. Tracer MP581 specifications**

<b>Weight</b>	15 lb (7 kg)
<b>Operating temperature</b>	From –40°F to 120°F (–40°C to 49°C)
<b>Storage temperature</b>	From –58°F to 203°F (–50°C to 95°C)
<b>Humidity</b>	10–90% non-condensing
<b>Altitude</b>	6500 ft (2000 m)
<b>Installation</b>	Category 3
<b>Pollution</b>	Degree 2
<b>High-voltage power requirements</b>	North America: 120 Vac, 1 A maximum, 1 phase
<b>Weight</b>	Mounting surface must be able to support 25 lb (12 kg)
<b>Analog to digital conversion</b>	12 bit
<b>Digital to analog conversion</b>	12 bit
<b>Microprocessor</b>	Motorola MC68332
<b>Processor clock speed:</b>	20 MHz
<b>Memory</b>	RAM: 256 kB (16-bit word) EEPROM: 256 kB (8-bit word) Flash: 1 MB (16-bit word)
<b>Clock</b>	Crystal controlled 32.768 kHz
<b>Battery</b>	None required

## Selecting a mounting location

Make sure that the location meets the operating environment requirements and clearance requirements described in the following sections. The Tracer MP581 controller must be installed indoors. Trane recommends locating the Tracer MP581 controller in the same room (within 20 ft) of the controlled equipment to reduce wiring costs.

### CAUTION

#### Equipment damage!

**Install the Tracer MP581 in a location that is out of direct sunlight. Failure to do so may cause the Tracer MP581 to overheat.**

### Operating environment requirements

Make sure that the operating environment conforms to the specifications listed in Table 14.

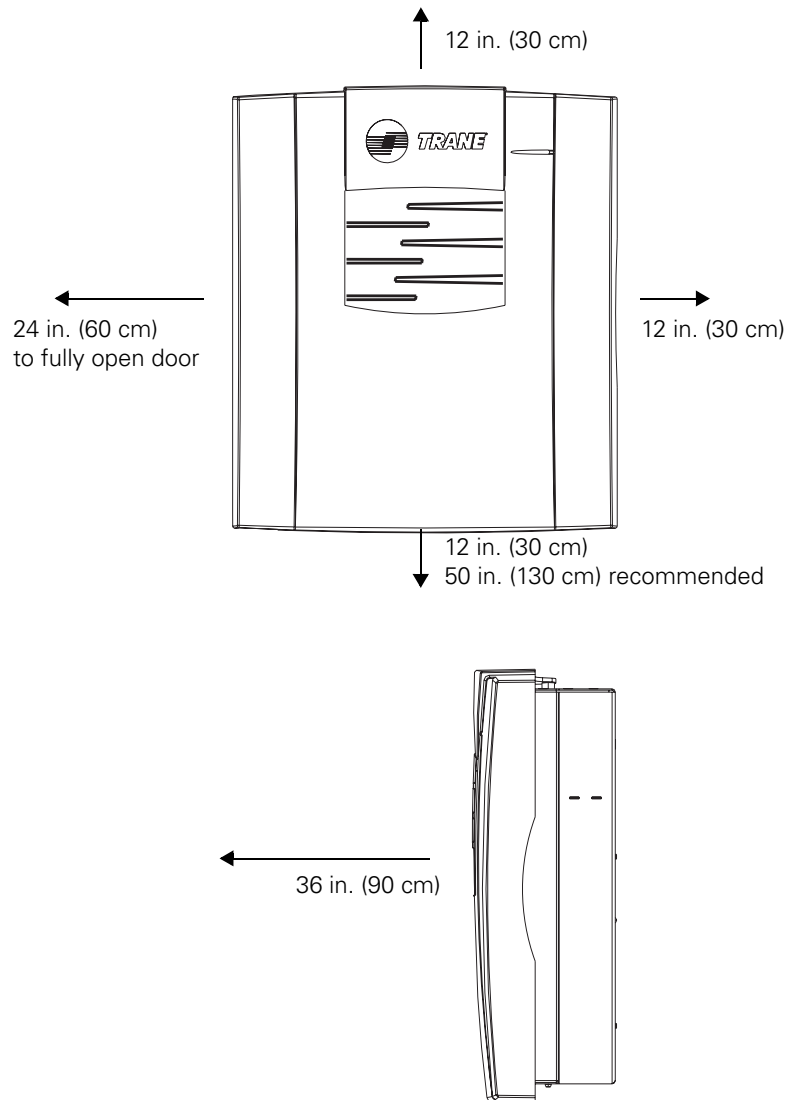
**Table 14. Operating environment specifications**

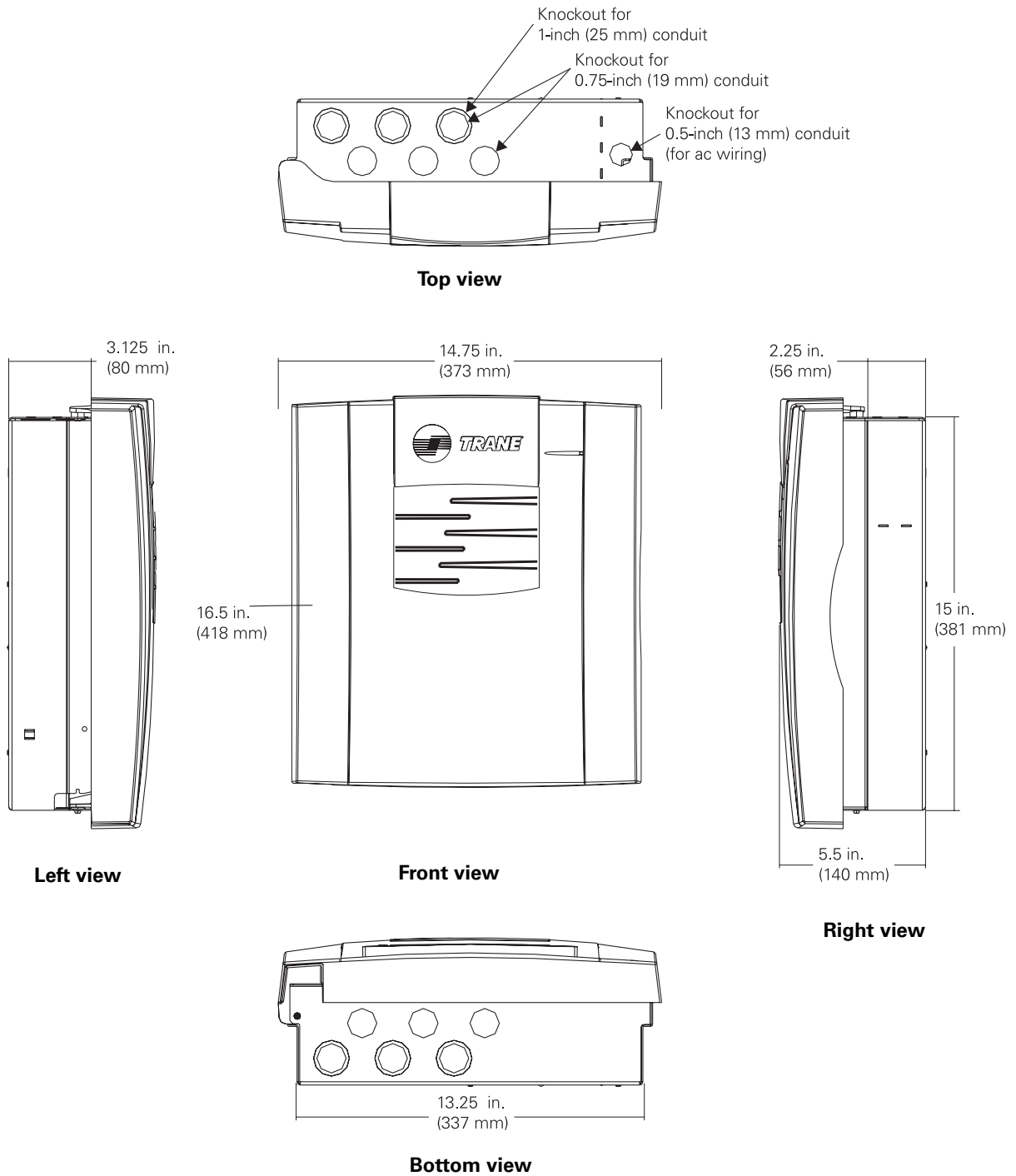
<b>Temperature</b>	From -40°F to 120°F (-40°C to 49°C)
<b>Humidity</b>	10–90% non-condensing
<b>Altitude</b>	6500 ft (2000 m)
<b>High-voltage power requirements</b>	North America: 98–132 Vac, 1 A maximum, 1 phase
<b>Weight</b>	Mounting surface must be able to support 25 lb (12 kg)

### Clearances and dimensions

Make sure that the mounting location has enough room to meet the minimum clearances shown in Figure 26. Figure 27 on page 57 shows the dimensions of the Tracer MP581 enclosure.

**Figure 26. Minimum clearances for enclosure**



**Figure 27. Tracer MP581 enclosure dimensions**

**Note:**

Six of the twelve knockouts are dual-sized knockouts for 1-inch (25 mm) and 0.75-inch (19 mm) conduit.

## Mounting the back of the enclosure

The back of the enclosure is shipped with the termination board installed inside it.

### IMPORTANT

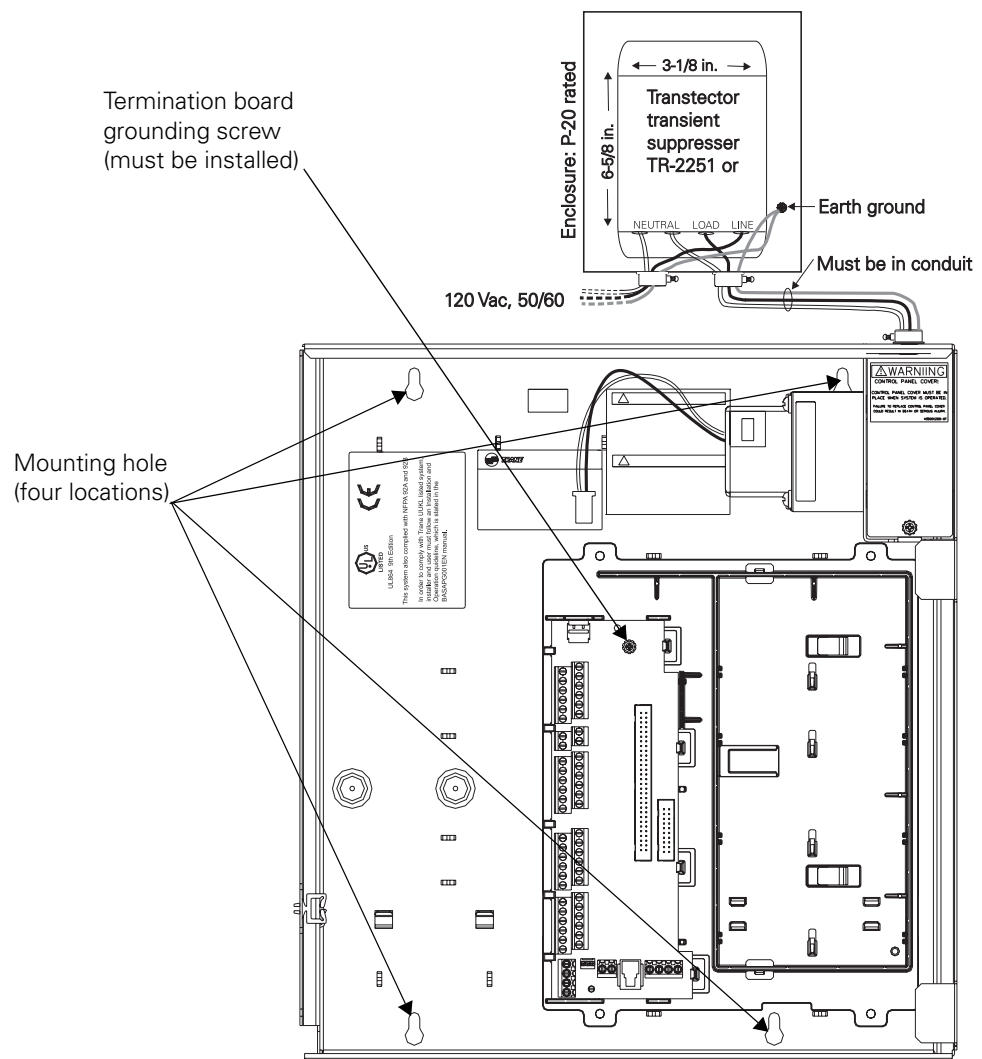
The termination board should be shipped with the grounding screw installed. Verify this by checking the location shown in Figure 28.

The enclosure door is shipped separately. If the door has already been attached to the enclosure back, remove it.

To mount the enclosure:

1. Using the enclosure as a template, mark the location of the four mounting holes on the mounting surface (see Figure 28).

**Figure 28. Enclosure mounting holes**



2. Set the enclosure aside and drill holes for the screws at the marked locations.

Drill holes for #10 (5 mm) screws or #10 wall anchors. Use wall anchors if the mounting surface is dry wall or masonry.

3. Insert wall anchors if needed.
4. Secure the enclosure to the mounting surface with the supplied #10 (5 mm) screws.

## Wiring high-voltage ac power

Table 15 lists the available Tracer MP581 model. You can find the model number on the shipping label or on the product label inside the enclosure.

**Table 15. Tracer MP581 models**

Model Number	Description
BMTM000DAB00	Tracer MP581 controller, 120 Vac, UUKL

### Circuit requirements

To ensure proper operation of the Tracer MP581, install the power supply circuit in accordance with the following guidelines:

- The Tracer MP581 must receive high-voltage power from a dedicated power circuit. Failure to comply may cause control malfunctions.
- A disconnect switch for the dedicated power circuit must be near the controller, within easy reach of the operator, and marked as the disconnecting device for the controller.
- High-voltage power-wire conduits or wire bundles must not contain input/output wires. Failure to comply may cause the controller to malfunction due to electrical noise.
- High-voltage power wiring must comply with the National Electrical Code (NEC) and applicable local electrical codes.
- High-voltage power wiring requires three-wire 120/230 Vac service. Use copper conductors only.

---

**Note:**

The voltage utilization range for the Tracer MP581 transformer is 120 Vac. The panel detects whether the current is 50 or 60 cycle.

## Wiring high-voltage power

### ⚠ WARNING

#### Hazardous voltage!

Before making electrical connections, lock open the supply-power disconnect switch. Failure to do so could result in death or serious injury.

### CAUTION

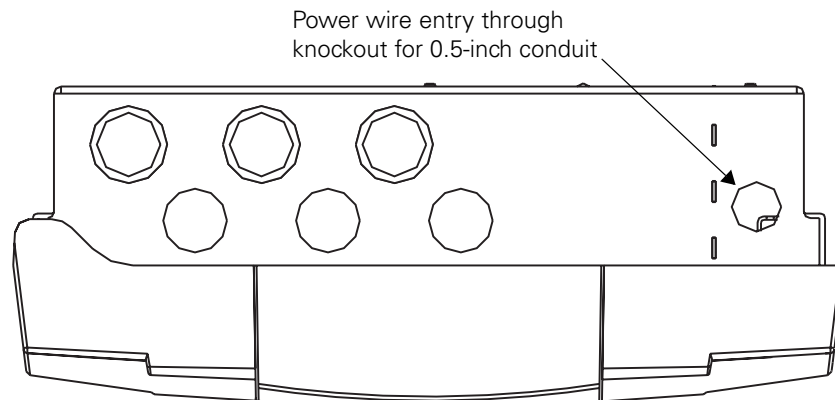
#### Use copper conductors only!

Unit terminals are designed to accept copper conductors only. Other conductors may cause equipment damage.

To connect high-voltage power wires:

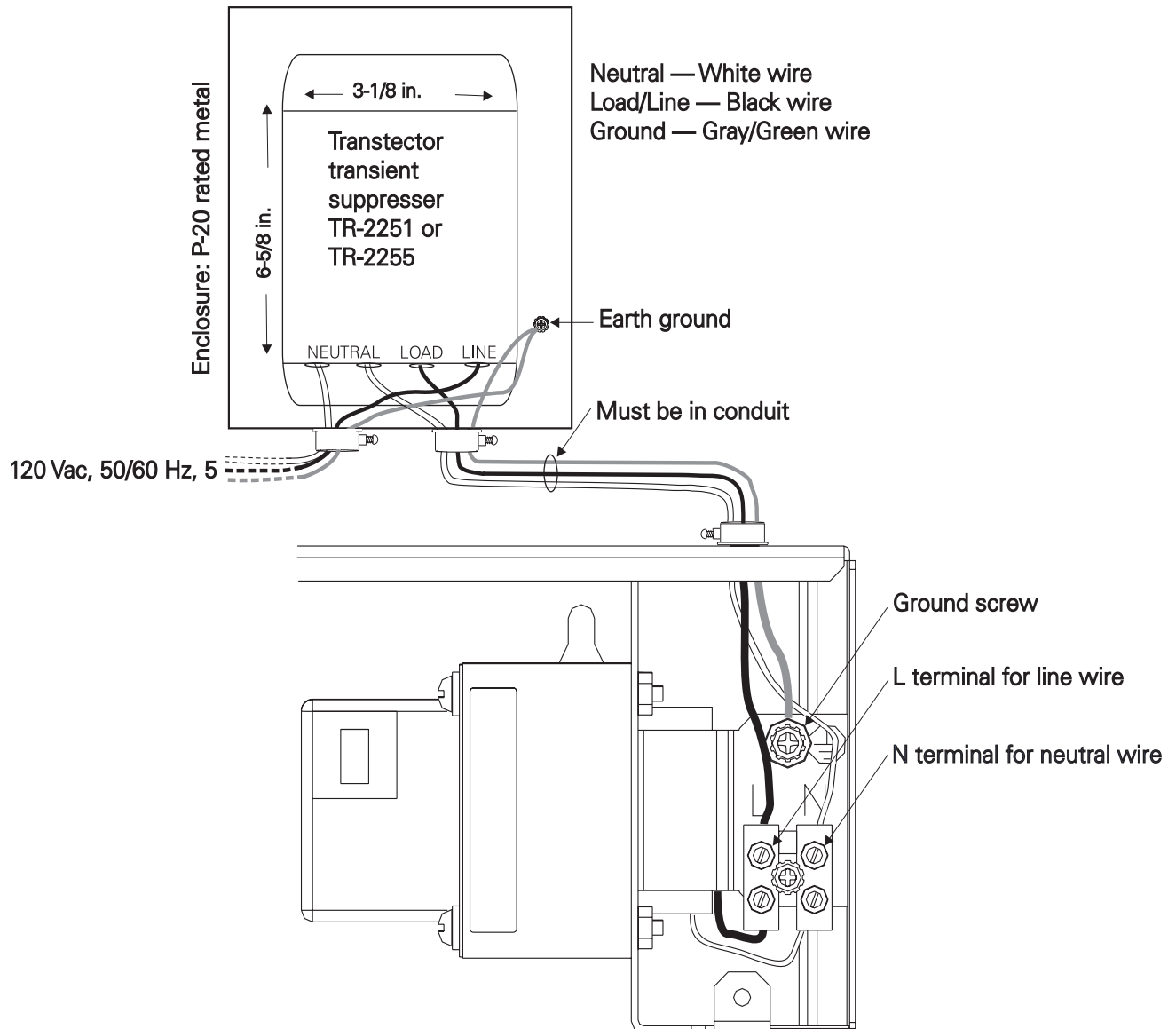
1. Lock open the supply-power disconnect switch.
2. At the top right corner of the enclosure, remove the knockout and install 0.5-inch (13 mm) conduit (see Figure 29).

**Figure 29. Knockout for high-voltage power wires**



3. Open or remove the Tracer MP581 door if it is already installed.
4. Inside of the enclosure at the top-right corner, remove the high-voltage area cover plate.
5. Feed the high-voltage power wires into the enclosure.
6. Connect the line wire to the L terminal as shown in Figure 30 on page 61.
7. Connect the neutral wire to the N terminal.
8. Connect the green ground wire to the chassis ground screw. The ground wire must be continuous back to the circuit-breaker panel.
9. Replace the cover plate.



**Figure 30. Terminal block for high-voltage power wires**


**⚠ WARNING**

**Hazardous voltage!**

**The cover plate must be in place when the controller is operating. Failure to replace the cover plate could result in death or serious injury.**

10. On a label, record the location of the circuit-breaker panel and the electrical circuit. Attach the label to the cover plate.

## EMI/RFI considerations

Take care to isolate HVAC controllers from electromagnetic interference (EMI) and radio frequency interference (RFI). Such interference can be caused by radio and TV towers, hospital diagnostic equipment, radar equipment, electric power transmission equipment, and so on. In addition, take care to prevent the Tracer MP581 controller from radiating EMI and/or RFI.

The Tracer MP581 is equipped with EMI/RFI filters that trap RFI to ground. In most situations, a good earth ground will reduce EMI/RFI problems by acting as a drain for EMI and RFI. If the Tracer MP581 is receiving or radiating interference, make sure that the earth ground is good. Do not assume that the building conduit is an adequate ground.

### Checking the earth ground

Though a proper earth ground is especially important in areas of high EMI or RFI, always check the quality of the ground, regardless of location.

#### **⚠ WARNING**

#### **Hazardous voltage!**

**The cover plate must be in place when the controller is operating. Failure to replace the cover plate could result in death or serious injury.**

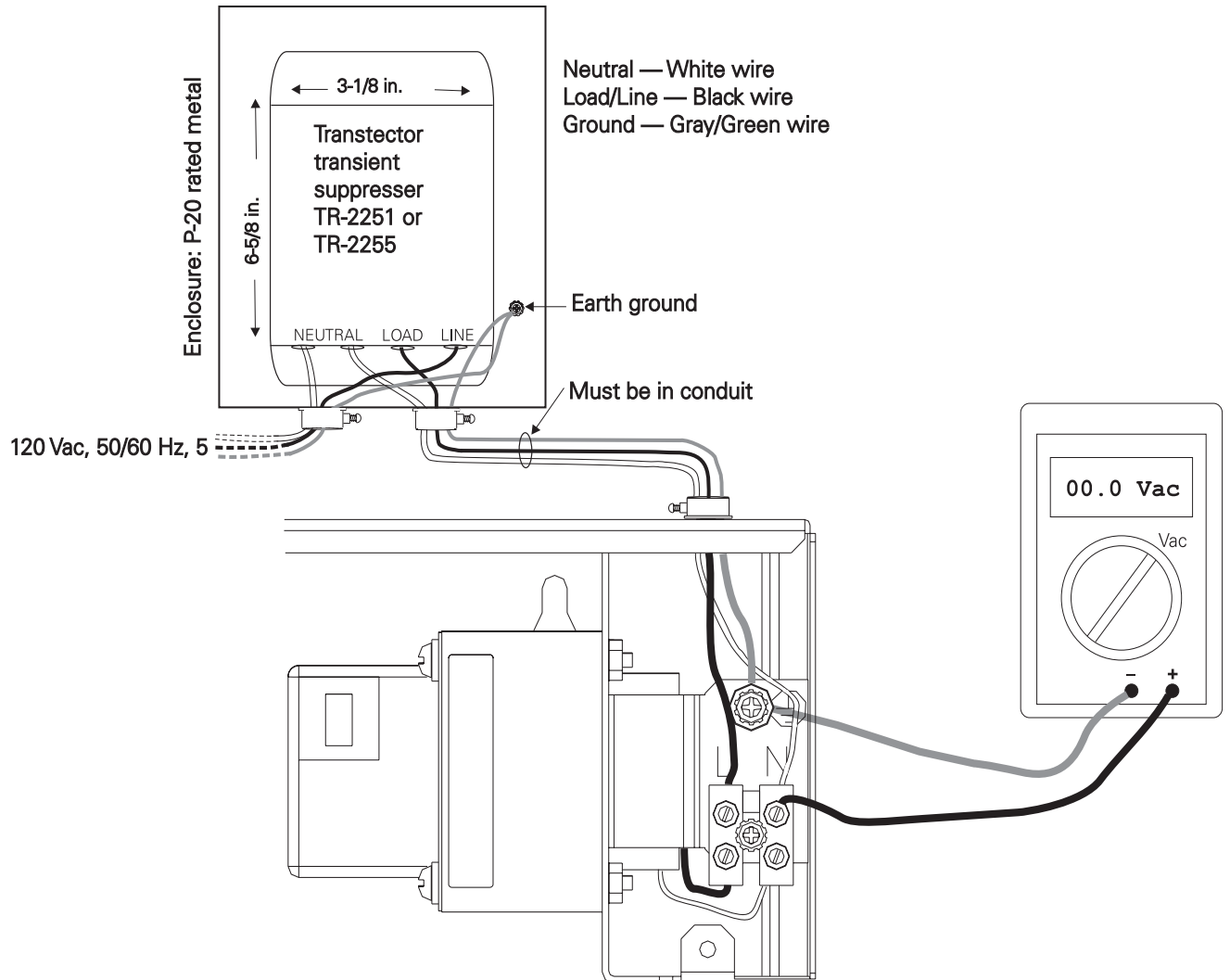
**If the earth ground has a voltage of more than 4 Vac, use a different ground. Failure to do so could result in death or serious injury.**

To check the quality of the earth ground:

1. Open the enclosure door.
2. Inside of the enclosure at the top-right corner, remove the high-voltage area cover plate.
3. Measure the ac voltage between the earth ground and the neutral terminal, as shown in Figure 31 on page 63.

Ideally, the voltage should be 0 Vac. Find a different ground if the voltage exceeds 4 Vac. A higher voltage may result in:

- Danger to people touching the enclosure
  - Erratic communications
  - Erratic equipment operation (Because noise may affect voltage levels at the inputs—the controller interprets input noise as changes in temperature, humidity, pressure, and so on.)
4. Replace the cover plate.

**Figure 31. Checking the earth ground**


## Wiring inputs and outputs

The Tracer MP581 enclosure is designed to simplify the wiring and configuration of inputs and outputs by providing a large space for routing wires and by eliminating the need to manipulate jumpers. Table 16 lists Tracer MP581 inputs and outputs.

**Table 16. Inputs and outputs**

Type	Number	Description
Universal inputs	12	Dry-contact binary, thermistor, 0–20 mA, 0–10 Vdc, linear resistance. The first four inputs can be used directly with resistance temperature detectors (RTDs).
Static pressure input	1	Differential pressure sensor, 5 Vdc, 0–5 in. wc
Binary outputs	6	Powered relay contacts, 6 VA at 24 Vac
Analog outputs	6	0–10 Vdc or 0–20 mA

### Input/output wiring guidelines

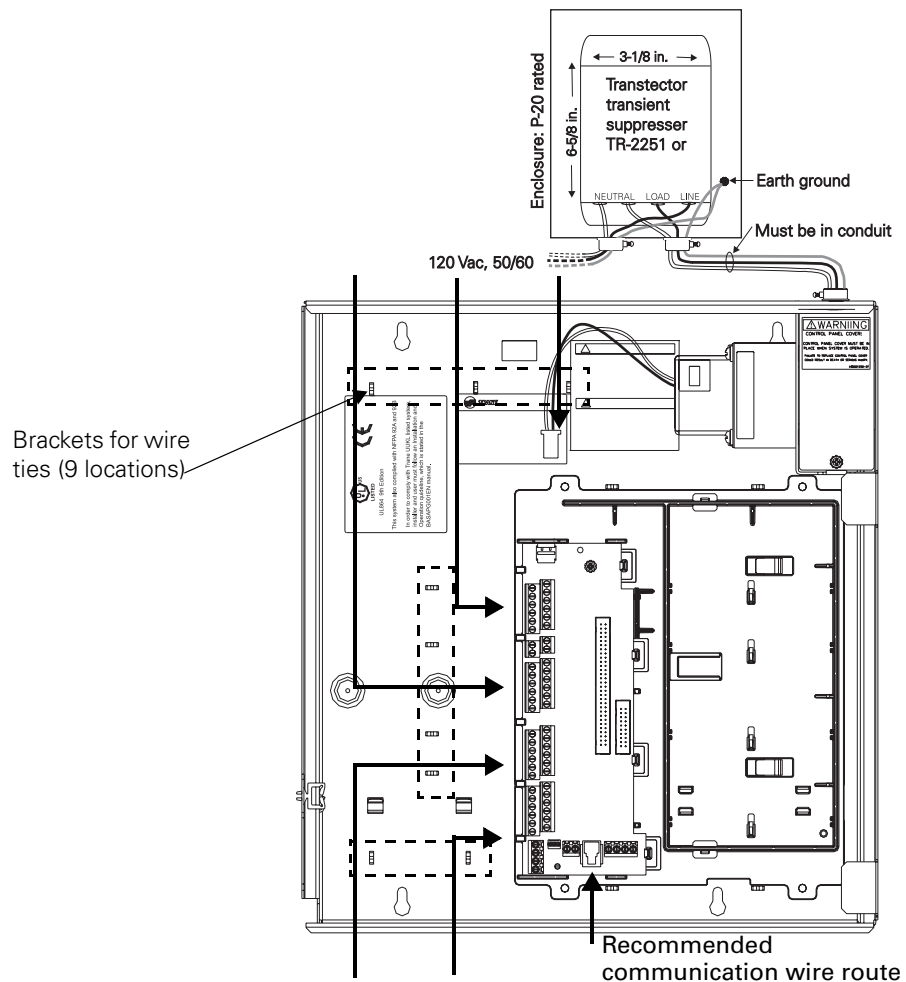
Input/output wiring must meet the following guidelines:

- Wiring must conform with the National Electrical Code and local electrical codes.
- Use only 18 AWG twisted-pair wire with stranded, tinned-copper conductors.
- Binary input/output wires must not exceed 1,000 ft (300 m).
- Analog input wires must not exceed 300 ft (100 m) for thermistors and 0–10 Vdc inputs and 1,000 ft (300 m) for 0–20 mA inputs.
- Analog output wires must not exceed 1,000 ft (300 m) for 0–10 Vdc outputs and 0–20 mA outputs.
- Do not run input/output wires in the same wire bundle with high-voltage power wires. Running input/output wires with 24 Vac power wires is acceptable, but the input wire must be shielded.
- Terminate input/output wires before installing the main circuit board (see “Installing the circuit board” on page 76).

## Wire routing

Figure 32 shows how to route input/output wires through the enclosure. It also shows the locations of wire-tie brackets. See Figure 27 on page 57 for knockout locations and dimensions. Metal conduit may be required by local codes when running input/output wires.

**Figure 32. Wire routing**



## Providing low-voltage power for inputs and outputs

The Tracer MP581 controller can provide low-voltage power to inputs and outputs. Figure 33 on page 66 shows the location of the low-voltage screw terminals on the termination board. The following limitations apply:

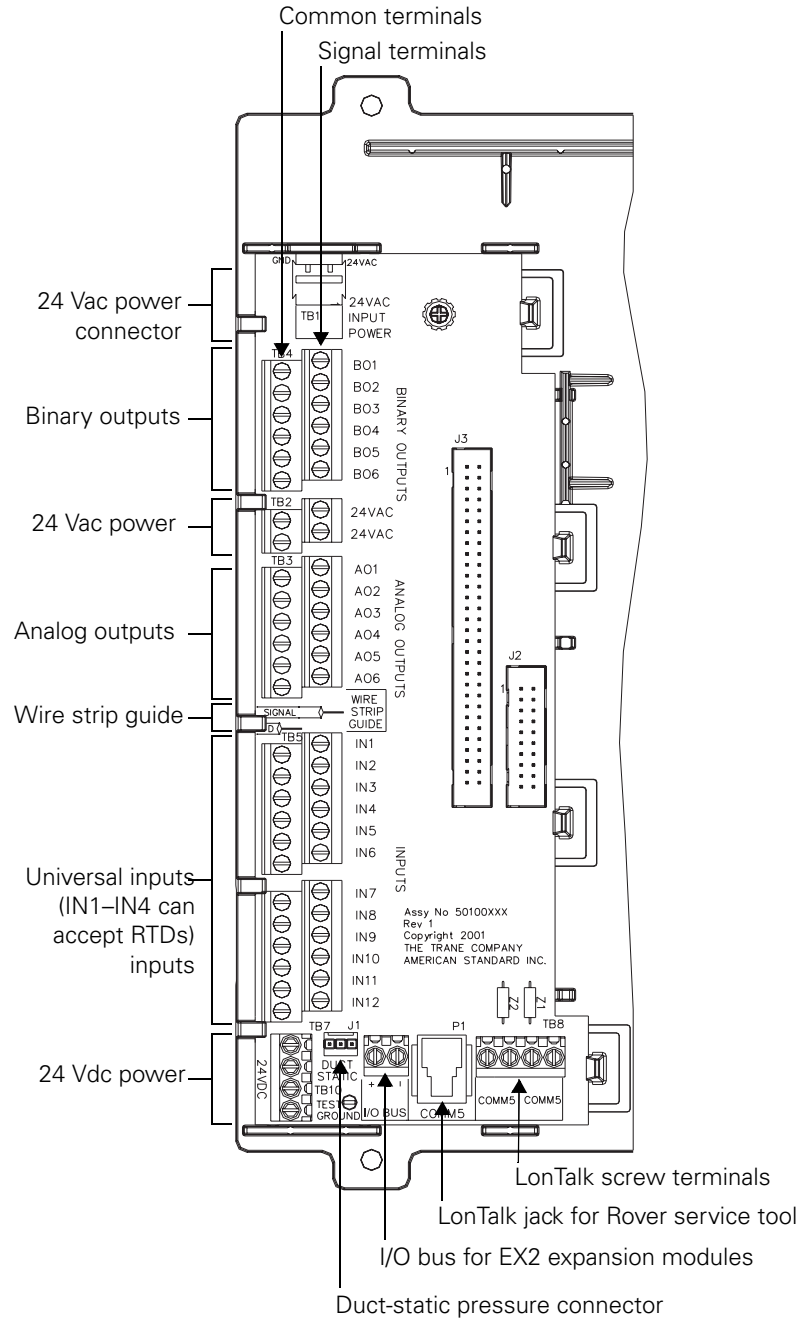
- Four 24 Vdc screw terminals supply a total of up to 250 mA of power.
- Two 24 Vac screw terminals supply a total of up to 17 VA of power. The 50 VA of available power supplies both the 24 Vac screw terminals and binary outputs.

Note that more than one input or output can receive power from a given screw terminal. The only limitation is the total amount of power supplied.

### Screw terminal locations

Figure 33 shows screw terminal locations on the termination board. The top row of screw terminals is for signal wires, and the bottom row of screw terminals is for common wires. To make sure that the wires lie flat, use the wire strip guide on the termination board to strip input/output wires to the correct length.

**Figure 33. Screw-terminal locations**



## Wiring universal inputs

The Tracer MP581 controller has 12 universal inputs. Use the Rover service tool to configure inputs for analog or binary operation.

The common terminals on the Tracer MP581 termination board are connected to the metal enclosure by means of a ground screw. Shield wires should be connected to a common terminal. Table 17 shows the load the Tracer MP581 places on sensors.

**Table 17. Load placed on sensors**

Input type	Load on sensor
Vdc (linear)	21 k $\Omega$
mA (linear)	221 $\Omega$

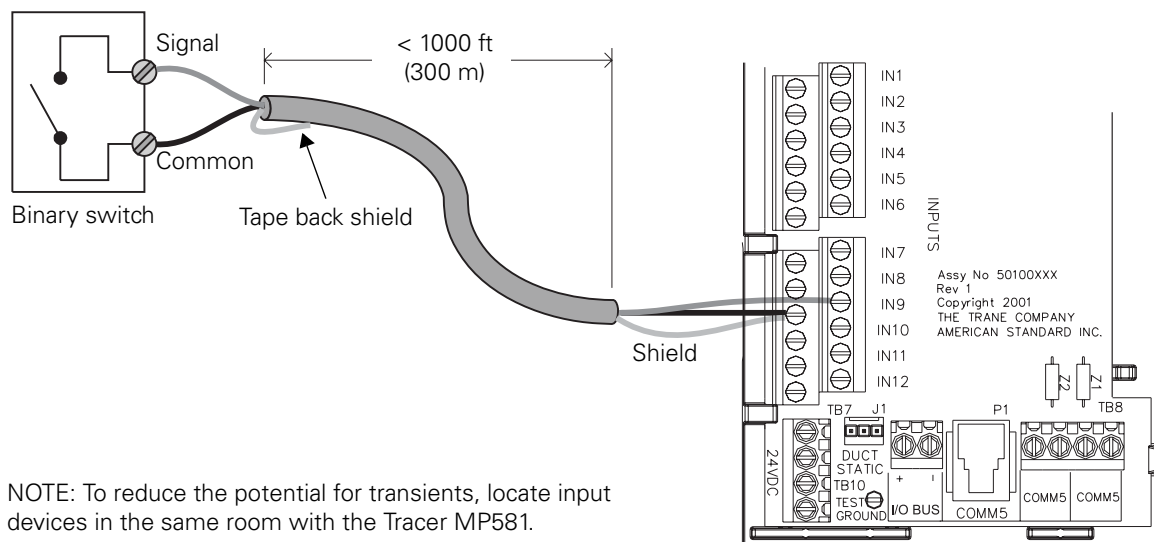
## Wiring binary inputs

Use binary inputs to monitor statuses, such as fan on/off and alarm resets.

To wire a binary input:

1. Connect the common wire to a common terminal as shown in Figure 34.  
 Note that, because the common terminals are in parallel, you can wire the common wire to any available common terminal.
2. Connect the shield wire to a common terminal at the termination board and tape it back at the input device.
3. Connect the signal wire to an available input terminal (IN1–IN12).
4. Use the Rover service tool to configure the input for binary operation.

**Figure 34. Wiring a binary input**



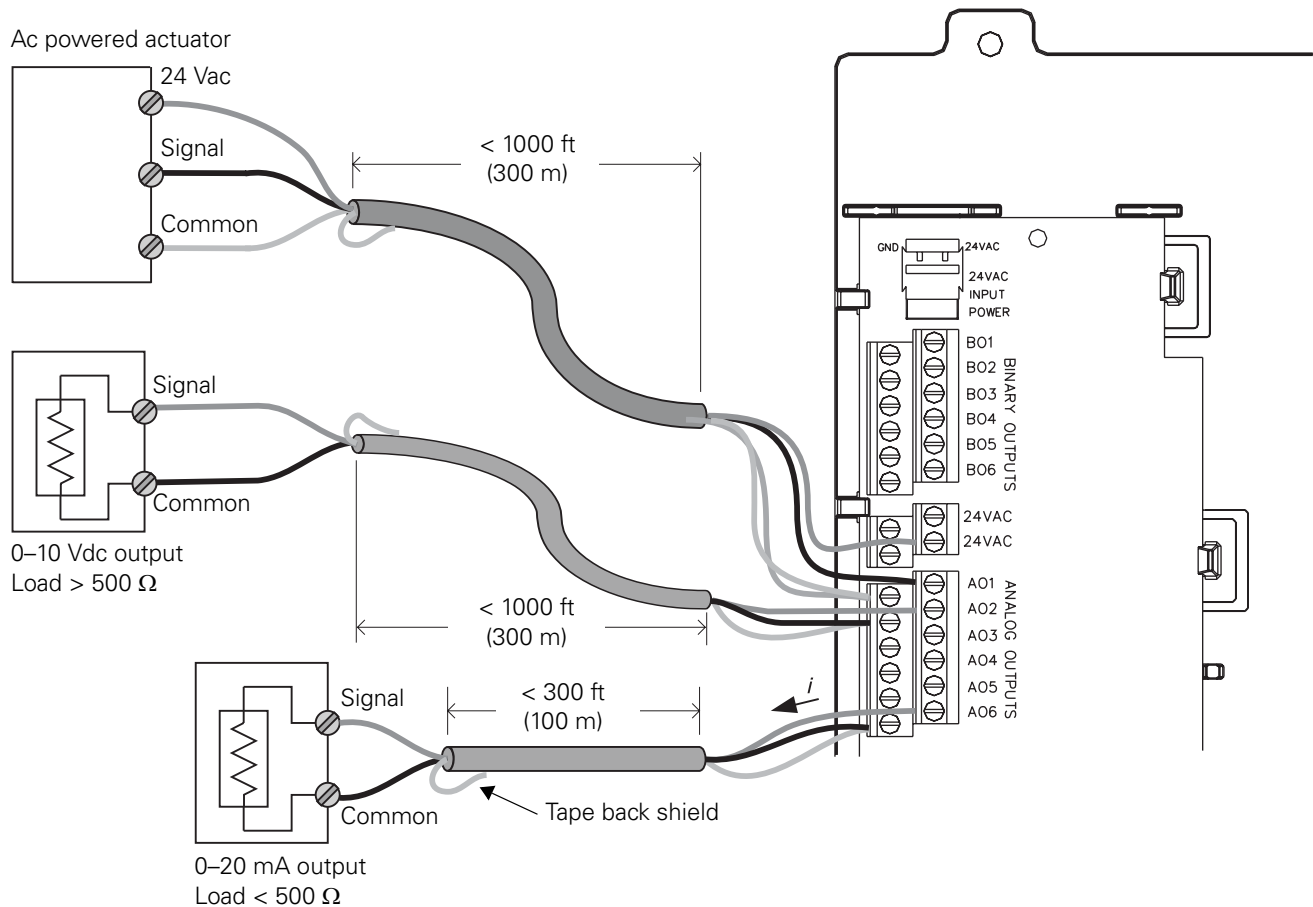
### Wiring analog outputs

The Tracer MP581 controller has six analog outputs. These outputs can be either 0–10 Vdc outputs or 0–20 mA outputs. Analog outputs control actuators and secondary controllers.

To wire an analog output:

1. For three-wire applications, use a 3-conductor cable with a shield. For two-wire applications, use a 2-conductor cable with a shield. Connect the shield to a common terminal at the termination board and tape it back at the output device (see Figure 35). Do not use the shield wire as the common connection.
2. Connect the signal wire to an available analog output terminal (AO1–AO6).
3. Connect the supply wire to a 24 Vac terminal as required.
4. Use the Rover service tool to configure the analog output.

**Figure 35. Wiring analog outputs**



NOTE: To reduce the potential for transients, locate output devices in the same room with the Tracer MP581.



## Wiring binary outputs

The Tracer MP581 controller has six binary outputs. These are powered outputs, not dry-contact outputs.

### **IMPORTANT**

**Use pilot relays for dry-contact outputs when the load is greater than 6 VA or has a current draw of greater than 0.25 A. Use powered outputs when the load is less than 6 VA or has a current draw of less than 0.25 A.**

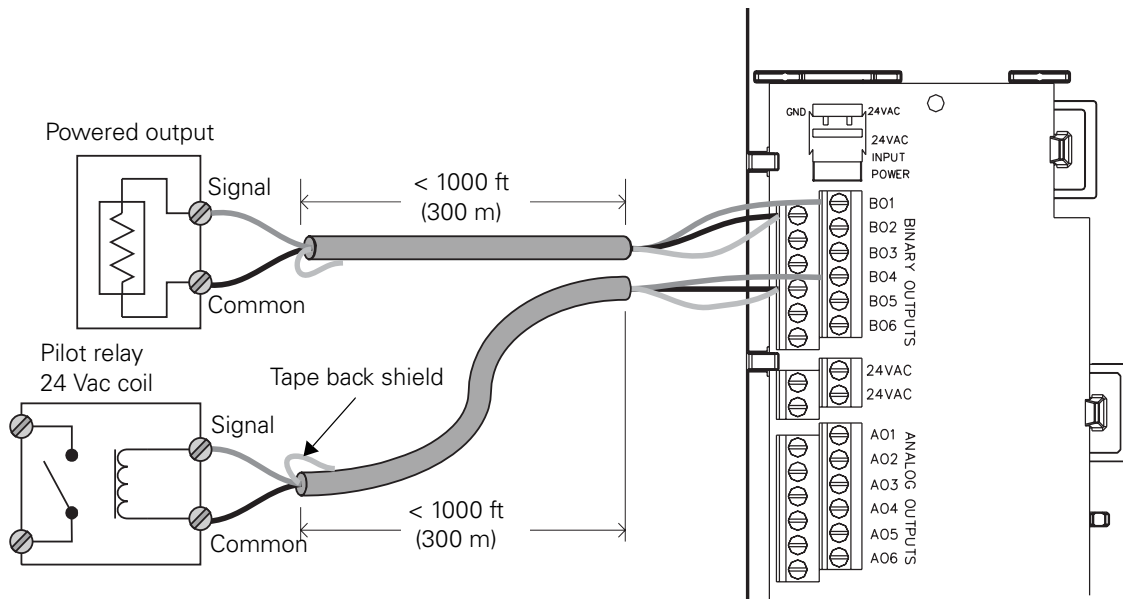
---

**Note:**

When controlling coil-based loads, such as pilot relays, do not forget to account for “inrush” current. Inrush current can be three (or more) times greater than the operating current. You can find information on inrush current for specific types of outputs in their product specifications.

To wire a binary output:

1. Connect the common wire to a common terminal as shown in Figure 36.
2. Connect the shield wire to a common terminal at the termination board and tape it back at the output device.
3. Connect the signal wire to an available binary output terminal (BO1–BO6).
4. Use the Rover service tool to configure the binary output.

**Figure 36. Wiring binary outputs**


NOTE: To reduce the potential for transients, locate output devices in the same room with the Tracer MP581.

## Checking binary inputs

To check binary inputs for proper operation:

1. Make sure that the sensor is connected and closed.
2. Set the multi-meter to measure Vac, then measure the voltage across the input connections at the signal and common screw terminals.

The measured voltage should be less than 0.1 Vac. If the voltage is greater than this, the input readings may change erratically.

3. Set the multi-meter to measure Vdc, then measure the voltage across the input at the signal and common screw terminals.

The measured voltage should be less than 0.1 Vdc. If the voltage is greater than this, the input readings may be offset.

## CAUTION

### Equipment damage!

**Continue to step 4 only if you completed steps 2 and 3 successfully. Measuring resistance may damage the meter if the voltage is too high.**

4. Set the multi-meter to measure resistance. If you completed steps 2 and 3 successfully, measure the resistance across the input.

The resistance should be less than 200  $\Omega$  when the binary input is closed and greater than 1 k $\Omega$  when it is open.

## Checking outputs

Follow the procedures in this section to test outputs for proper operation.

### IMPORTANT

**Perform the tests in this section before providing power to the termination board or installing the main circuit board. Failure to do so will result in incorrect multi-meter readings.**

To test outputs for proper operation, you need the following tools:

- Digital multi-meter
- Small flat-tip screwdriver

### Checking binary outputs

To check binary outputs for proper operation:

1. Set the multi-meter to measure Vac, then measure the voltage across the binary output at the common and signal screw terminals.

The measured voltage should be less than 0.1 Vac. If the voltage is greater than this, the load may turn on and off unexpectedly. Check for the following problems:

- A shared power supply may be incorrectly connected. Check the wire to make sure that no additional connections have been made.
  - The wire may have an induced voltage somewhere along its length.
2. Set the multi-meter to measure Vdc, then measure the voltage across the binary output at the common and signal screw terminals.  
  
The measured voltage should be less than 0.1 Vdc. If the it is greater than this, a shared power supply may be incorrectly connected. Check the wire to make sure that no additional connections have been made.

### CAUTION

#### Equipment damage!

**Continue to step 3 only if you completed steps 1 and 2 successfully. Measuring resistance may damage the meter if the voltage is too high.**

3. Set the multi-meter to measure resistance. If you completed steps 1 and 2 successfully, measure the resistance across the binary output to confirm that there are no shorts and no open circuits.

Resistance is load dependent. Pilot relays have a relatively low resistance of less than 1 k $\Omega$  but some actuators have a high resistance. Check to see what kind of binary output is connected before checking for open and short circuits.

### Checking 0–10 Vdc analog outputs

To check 0–10 Vdc analog outputs for proper operation:

## Chapter 5 Installing the Tracer MP581 programmable controller

1. Make sure that the actuator is connected but powered off.
2. Set the multi-meter to measure Vac, then measure the voltage across the analog output at the signal and common screw terminals.

The measured voltage should be less than 0.1 Vac. If the voltage is greater than this, the load may turn on and off unexpectedly. Check for the following problems:

- A shared power supply may be incorrectly connected. Check along the wire to make sure that no additional connections have been made.
  - The wire may have an induced voltage somewhere along its length.
3. Set the multi-meter to measure Vdc, then measure the voltage across the analog output at the signal and common screw terminals.

The measured voltage should be less than 0.1 Vdc. If the voltage is greater than this, a shared power supply may be incorrectly connected. Check along the wire to make sure that no additional connections have been made.

### CAUTION

#### Equipment damage!

**Continue to step 4 only if you completed steps 2 and 3 successfully.  
Measuring resistance may damage the meter if the voltage is too high.**

4. Set the multi-meter to measure resistance. If you completed steps 2 and 3 successfully, measure the resistance across the analog output at the signal and common screw terminals.

The resistance should be greater than 500  $\Omega$ . (The analog output will not be able to reach 10 Vdc if the load resistance is less than 500  $\Omega$ .)

### Checking 0–20 mA analog outputs

To check 0–20 mA analog outputs for proper operation:

1. Make sure that the actuator is connected but powered off.
2. Set the multi-meter to measure Vac, then measure the voltage across the analog output at the signal and common screw terminals.

The measured voltage should be less than 0.1 Vac. If the voltage is greater than this, the load may turn on and off unexpectedly. Check for the following problems:

- A shared power supply may be incorrectly connected. Check along the wire to make sure that no additional connections have been made.
- The wire may have an induced voltage somewhere along its length.

3. Set the multi-meter to measure Vdc, then measure the voltage across the analog output at the signal and common screw terminals.

The measured voltage should be less than 0.1 Vdc. If the voltage is greater than this, a shared power supply may be incorrectly connected. Check along the wire to make sure that no additional connections have been made.

## Wiring LonTalk to the Tracer MP581

### IMPORTANT

When installing the Tracer MP581 controller in areas of high electromagnetic interference (EMI) and radio frequency interference (RFI), follow the additional installation instructions in “EMI/RFI considerations” on page 62.

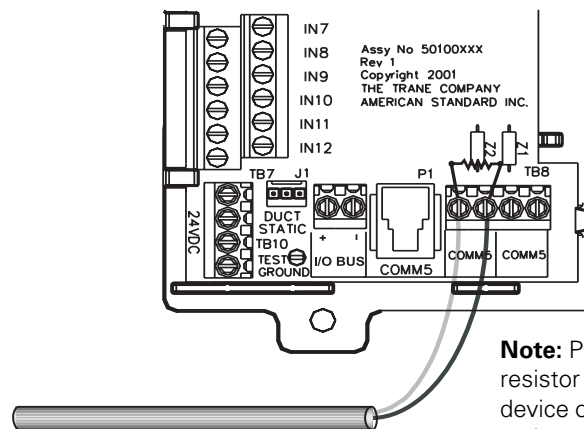
#### Note:

Although LonTalk links are not polarity sensitive, we recommend that you keep polarity consistent throughout the site.

To wire the LonTalk link:

1. At the first Tracer MP581 on the link, complete the following steps:
  - Connect the white wire to the first (or third) LonTalk screw terminal as shown in Figure 37.
  - Connect the black wire to the second (or fourth) LonTalk screw terminal.
  - If this is the first LonTalk controller on the daisy chain, place a 105  $\Omega$  termination resistor across the LonTalk screw terminals.

**Figure 37. Wiring the first device to the LonTalk connection on the termination board**



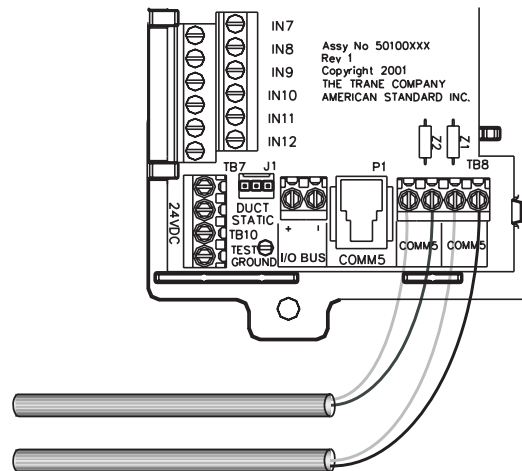
**Note:** Place a 105  $\Omega$  termination resistor at the first and last LonTalk device on the daisy chain. Termination resistors require insulation, such as heat shrink tubing, to avoid accidental shorts to other conductors.

2. At the next Tracer MP581 (or other LonTalk controller) on the link:
  - Connect the white wires to the first and third LonTalk screw terminals (as shown in Figure 38 on page 75).
  - Connect the black wires to the second and fourth LonTalk screw terminals.

3. At the last controller on the LonTalk link:

- Connect the white wire to the first LonTalk screw terminal.
- Connect the black wire to the second LonTalk screw terminal.
- Place a 105  $\Omega$  termination resistor across the LonTalk screw terminals.

**Figure 38. Wiring the next device to the LonTalk connection on the termination board**



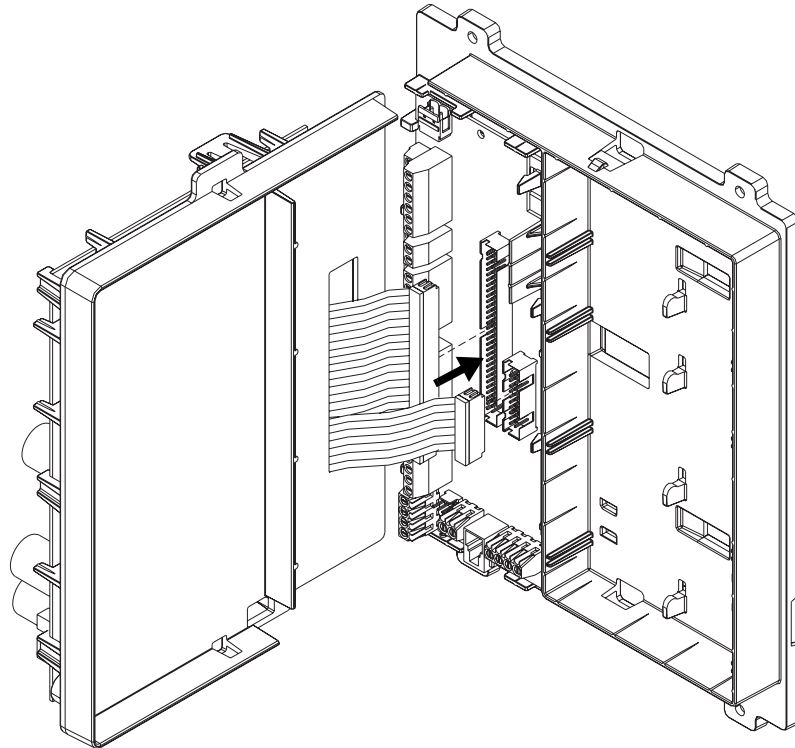
## Installing the circuit board

The main circuit board is not installed in the Tracer MP581 enclosure when it ships. You can store the circuit board in the office while the enclosure is mounted and wired. After wiring has been completed, connect the circuit board to the termination board.

To install the circuit board:

1. Open the enclosure door.
2. Verify that the 24 Vac power cable is not connected to the termination board (see Figure 41 on page 78).
3. Hold the top plastic frame, which holds the circuit board, at a 90° angle to the bottom frame as shown in Figure 39.

**Figure 39. Connecting the cables**



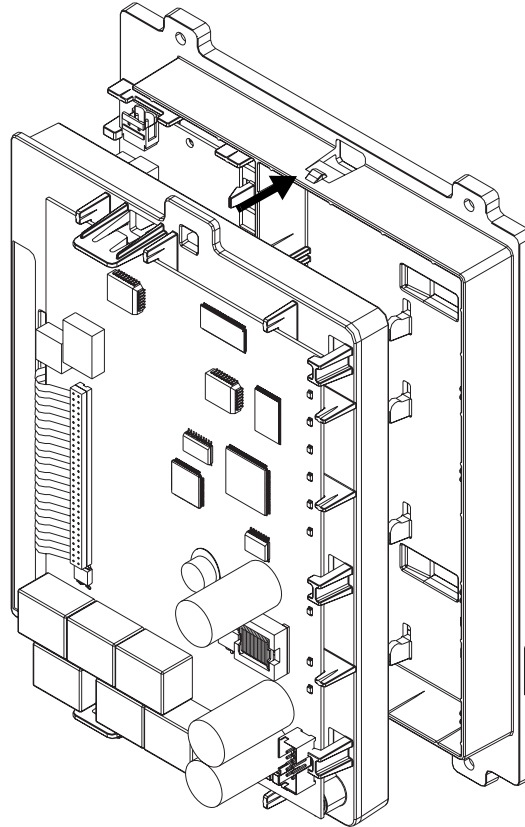
4. Connect the 60-pin cable to the 60-pin slot, then connect the 20-pin cable to the 20-pin slot.

The connectors fit only one way. If you have difficulty connecting them, make sure that the plastic grooves line up with the slots.



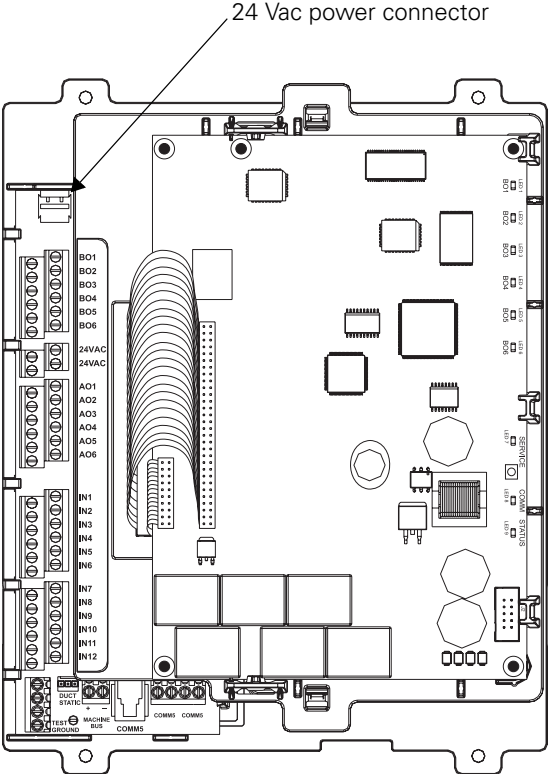
5. Align the snaps on the top frame with the mounting locks on the bottom frame, as shown in Figure 40, then push the two frames together. You will hear a click when the frames connect.

**Figure 40. Connecting the frames**



6. Locate the 24 Vac power connector on the termination board (see Figure 41 on page 78). Remove the mating plug with screw terminals.
7. Attach the 24 Vac power-supply cable to the screw terminals on the mating plug.
8. Connect the mating plug to the 24 Vac power connector on the termination board. The green status LED should light up.
9. Check status LEDs according to the information given in “Interpreting LEDs” on page 79.

Figure 41. 24 Vac power-supply cable connection



## Verifying operation and communication of the Tracer MP581

This chapter describes the location and function of the Service Pin button and the light-emitting diodes (LEDs) on the Tracer MP581 controller.

### Service Pin button

The Service Pin button is located on the main circuit board as shown in Figure 42. Use the Service Pin button in conjunction with a service tool or BAS to:

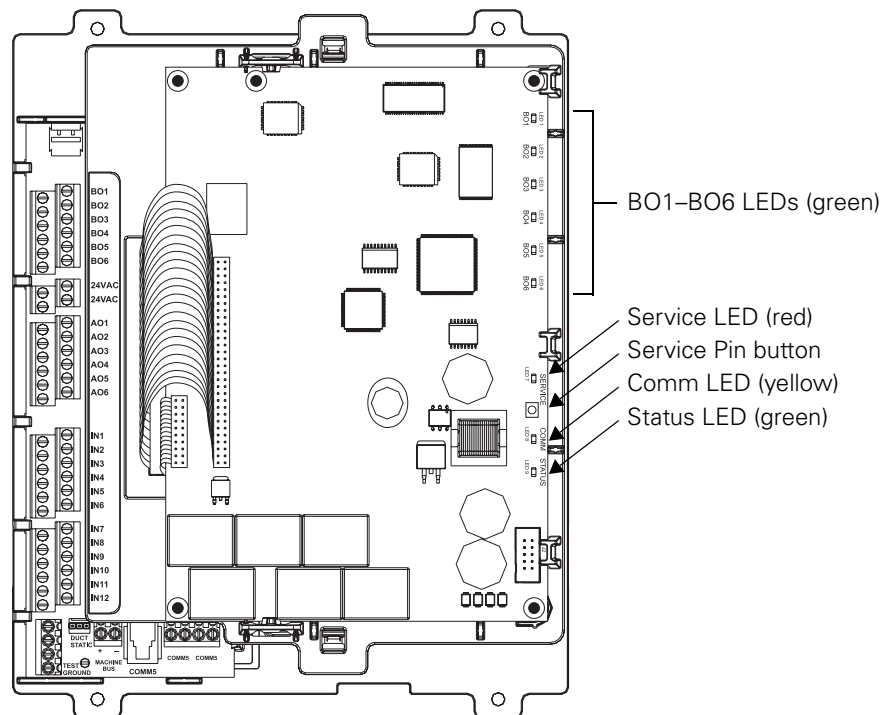
- Identify a device
- Add a device to the active group
- Verify PCMCIA communications
- Make the green Status LED “wink” to verify that the controller is communicating on the link

Refer to the *Rover Operation and Programming* guide, EMTX-SVX01D-EN, for information on how to use the Service Pin button.

### Interpreting LEDs

The information in this section will help you interpret LED activity. The location of each LED is shown in Figure 42.

**Figure 42. Service Pin button and LED locations**



## Binary output LEDs

The BO1–BO6 LEDs indicate the status of the six binary outputs. Table 18 describes binary output LED activity.

**Note:**

Each binary output LED reflects the status of the output relay on the circuit board. It may or may not reflect the status of the equipment the binary output is controlling. Field wiring determines whether the state of the binary output LED also applies to the status of the end device. Table 18 describes the LED states.

**Table 18. Binary output LEDs**

LED activity	Explanation
LED is on continuously	The relay output is energized.
LED is off continuously	The relay output is de-energized or there is no power to the board.

## Service LED

The red Service LED indicates whether the controller is operating normally. Table 19 describes Service LED activity.

**Table 19. Red Service LED**

LED activity	Explanation
LED is off continuously when power is applied to the controller	The controller is operating normally.
LED is on continuously when power is applied to the controller	The controller is not working properly, or someone is pressing the Service Pin button.
LED flashes once every second	The controller is not executing the application software because the network connections and addressing have been removed. <sup>1</sup>
<sup>1</sup> Restore the controller to normal operation using the Rover service tool. Refer to EMTX-SVX01D-EN for more information.	



## Status LED

The green Status LED indicates whether the controller has power applied to it. Table 20 describes Status LED activity.

**Table 20. Green Status LED**

LED activity	Explanation
LED is on continuously	Power is on (normal operation).
LED blinks (¼ second on, ¼ second off for 10 seconds)	The auto-wink option is activated, and the controller is communicating. <sup>1</sup>
LED blinks rapidly	Flash download is being received.
LED is off continuously	Either the power is off or the controller has malfunctioned.
<sup>1</sup> By sending a request from the Rover service tool, you can request the controller's green LED to blink ("wink"), a notification that the controller received the signal and is communicating.	

## Comm LED

The yellow Comm LED indicates the communication status of the Tracer MP581 controller. Table 21 describes Comm LED activity.

**Table 21. Yellow Comm LED**

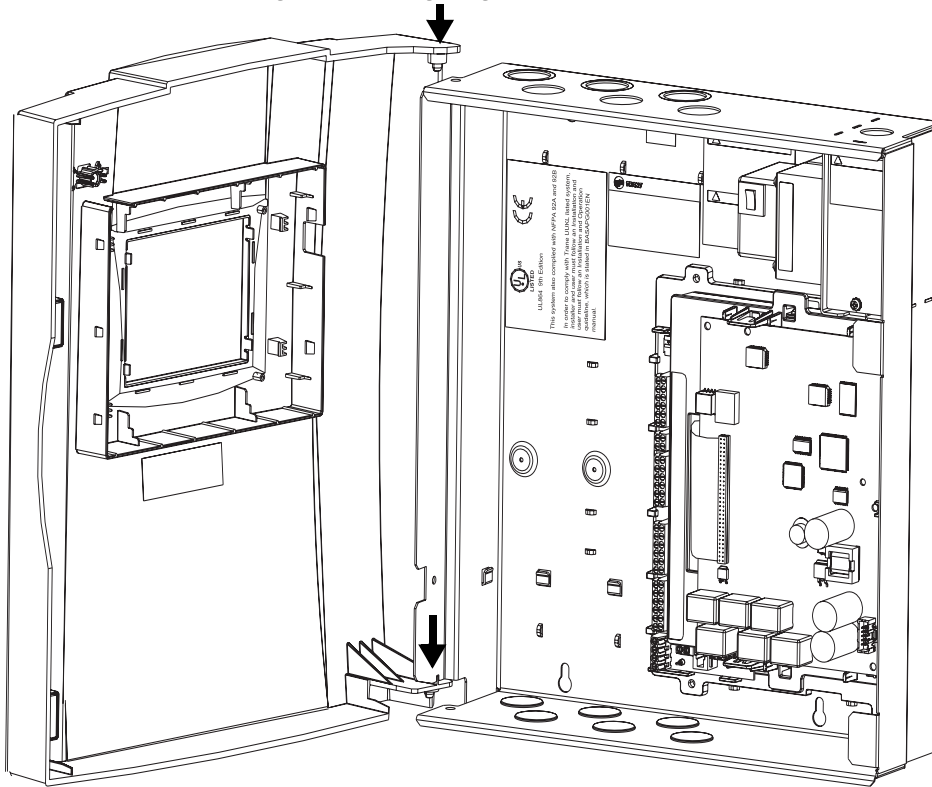
LED activity	Explanation
LED is off continuously	The controller is not detecting any communication (normal for stand-alone applications).
LED blinks	The controller detects communication (normal for communicating applications, including data sharing).
LED is on continuously	The LED may flash so fast that it looks as if it is on continuously. If this LED activity occurs at any time other than discovery, it indicates an abnormal condition. For example, the site may have excessive radio frequency interference (RFI).

## Installing the door

To install the enclosure door:

1. Unpack the door and check for missing or damaged parts.  
Check to make sure that the magnetic latches and touch screen (if ordered) are installed. Check for any cracks in the plastic.
2. Hold the door at a 90° angle from the enclosure as shown in Figure 43 on page 82.

**Figure 43. Aligning the enclosure door**



3. Align the hinge pegs on the door with the hinge holes on the enclosure.
4. Gently lower the door until it rests securely in the hinge holes.
5. Verify that the door swings freely on the hinges and that the magnetic latches hold the door securely when it is closed.

## Removing the door

Remove the door to simplify wiring or when upgrading the controller with a door-mounted operator display.

To remove the enclosure door:

1. Open the door to a 90° angle from the enclosure.



*Installing the door*

2. For doors with an operator display, disconnect the operator-display cable from operator display.
3. Lift the door to pull the hinges from the hinge holes.



*Chapter 5 Installing the Tracer MP581 programmable controller*





## Chapter 6

# Installing the EX2 expansion module

---

The EX2 is a field-installed expansion module for the Tracer MP581 programmable controller. Up to four EX2s with metal enclosure, model number 4950 0523, can be connected to a Tracer MP581. Each EX2 adds the following inputs and outputs to a Tracer MP581:

- Six universal inputs
- Four binary outputs
- Four analog outputs

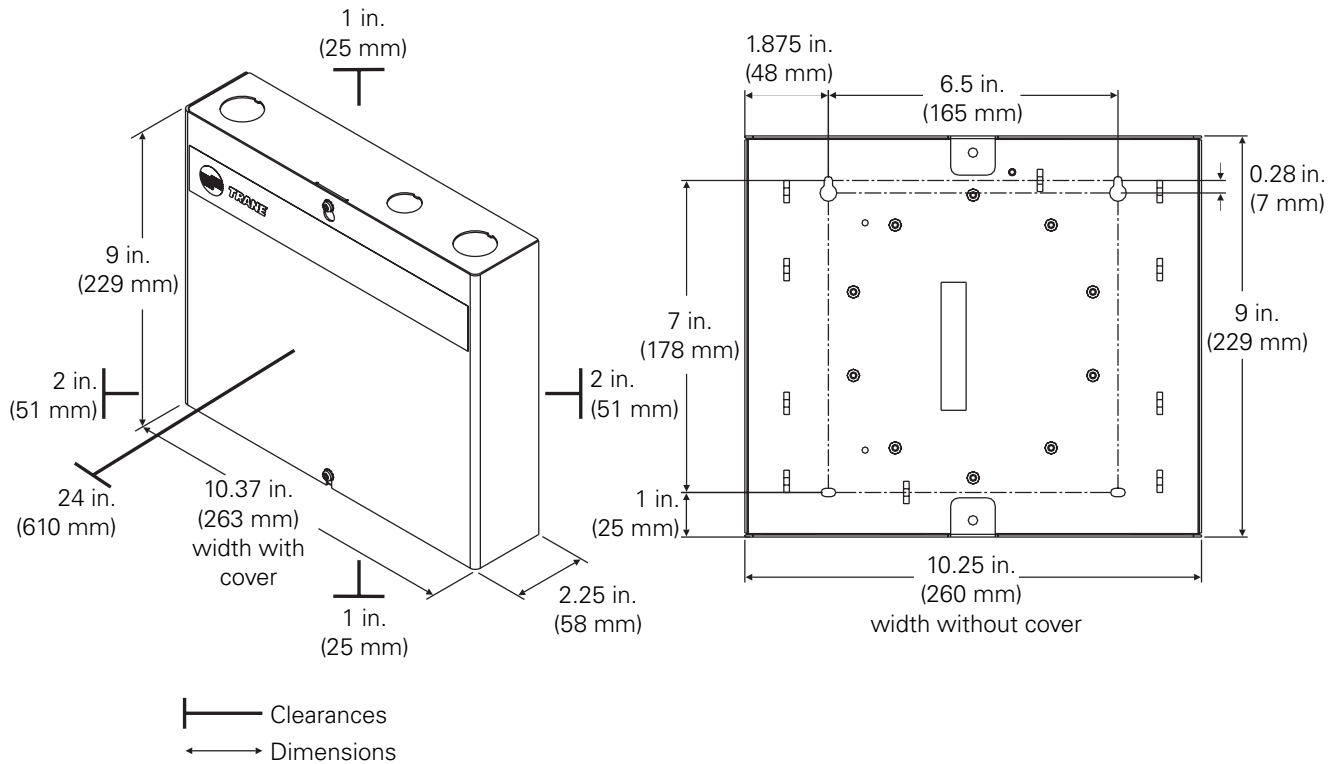
The enclosure package includes:

- EX2 circuit board fastened to the back piece of a metal enclosure
- Removable metal cover

Make sure that the operating environment conforms to the specifications listed in Table 22. Dimensions and clearances are illustrated in Figure 44 on page 86.

**Table 22. Operating environment specifications**

<b>Temperature</b>	From -40°F to 120°F (-40°C to 49°C)
<b>Humidity</b>	5–93%, non-condensing
<b>Power</b>	24 Vac, 50/60 Hz, 10 VA main board and 6 VA max per binary output
<b>Mounting Weight (frame-mount)</b>	Mounting surface must be able to support 2 lb (1 kg)
<b>Mounting Weight (metal enclosure)</b>	Mounting surface must be able to support 8 lb (4 kg)
<b>Altitude</b>	6,500 ft (2,000 m)
<b>Installation</b>	Category 3
<b>Pollution</b>	Degree 2

**Figure 44. Dimensions and clearances for metal-enclosure EX2**


## Storage environment

The storage environment must meet the following requirements:

- Temperature: From  $-40^{\circ}\text{F}$  to  $185^{\circ}\text{F}$  ( $-40^{\circ}\text{C}$  to  $85^{\circ}\text{C}$ )
- Relative humidity: 5–93%, non-condensing

## Mounting location

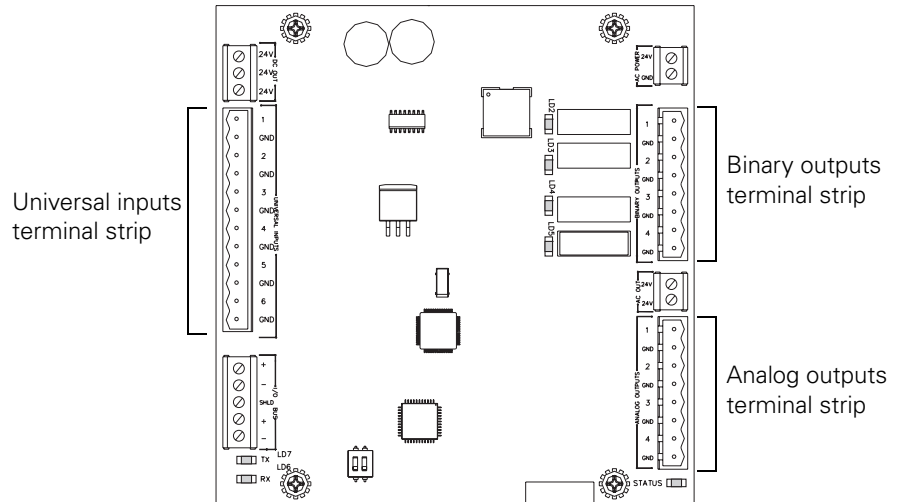
Trane recommends locating the EX2 module:

- In an environment protected from the elements
- Where public access is restricted to minimize the possibility of tampering or vandalism
- Near the controlled equipment to reduce wiring costs
- Where it is easily accessible for service personnel
- In conduit, in the same room, and no more than 20 ft (6.1 m) from the FACP

## Terminal strips

The EX2 module is shipped with terminal strips already in place (Figure 45). If you need to replace the circuit board, you can transfer the terminal strips to the new board without rewiring.

**Figure 45. Terminal strip locations**

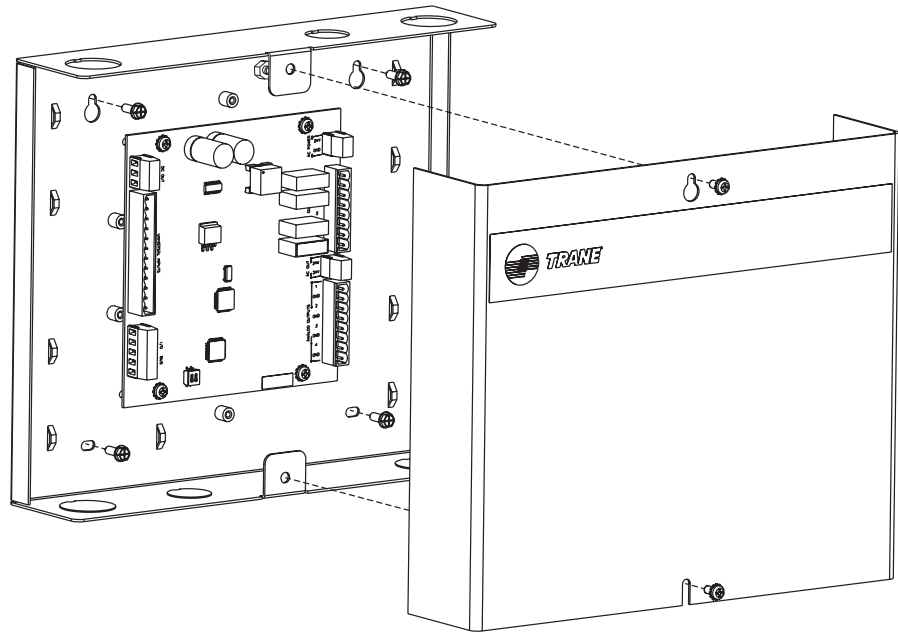


## Mounting the metal-enclosure module

To mount the enclosure:

1. Unscrew the two screws on the front of the enclosure and remove the cover.
2. Using the enclosure as a template, mark the location of the four mounting holes on the mounting surface (Figure 46 on page 88).
3. Set the enclosure aside and drill holes for the screws at the marked locations.
4. Drill holes for #10 (5 mm) screws or #10 wall anchors. Use wall anchors if the mounting surface is dry wall or masonry.
5. Insert wall anchors if needed.
6. Secure the enclosure to the mounting surface with #10 (5 mm) screws (not included).

Figure 46. Mounting the metal-enclosure EX2



## AC-power wiring

Use 16 AWG copper wire for ac-power wiring. All wiring must comply with National Electrical Code and local codes. Use a UL-listed Class 2 power transformer supplying a nominal 24 Vac. The transformer must be sized to provide adequate power to the EX2 module (10 VA) and outputs (a maximum of 6 VA per binary output).

Please read the warnings and cautions before proceeding.

### **⚠ WARNING**

#### **Hazardous voltage!**

**Before making line voltage electrical connections, lock open the supply-power disconnect switch. Failure to do so could result in death or serious injury.**

### **⚠ WARNING**

#### **Hazardous voltage!**

**Make sure that the 24 Vac transformer is properly grounded. Failure to do so could result in death or serious injury.**

**CAUTION****Equipment damage!**

Complete input/output wiring before applying power to the EX2 module. Failure to do so may cause damage to the module or power transformer due to inadvertent connections to power circuits.

**CAUTION****Equipment damage!**

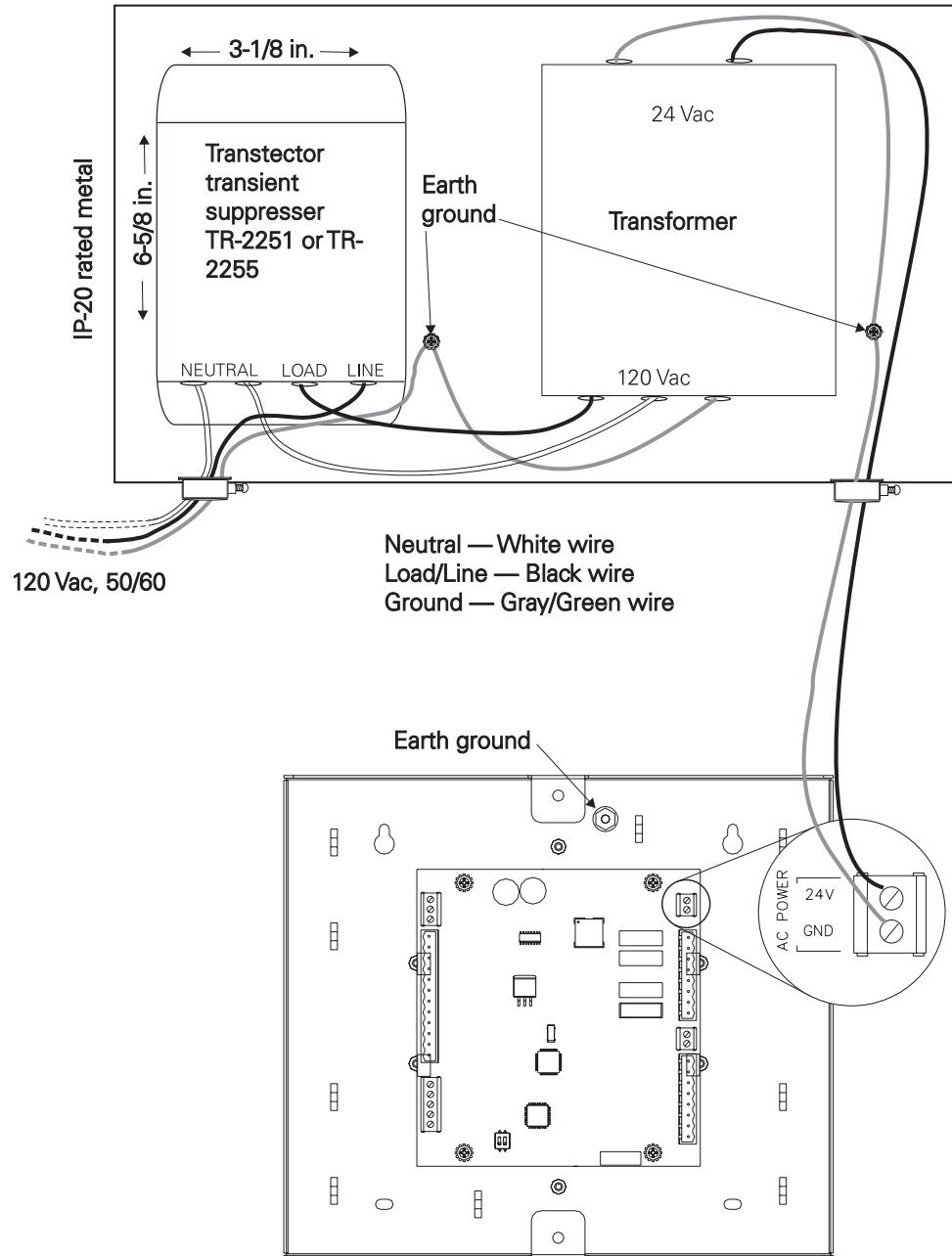
To prevent module damage, do not share 24 Vac between modules.

**Wiring AC-power to the metal-enclosure module**

Please read the preceding warnings and cautions. To connect ac-power wiring to the enclosure:

1. Remove the cover of the enclosure.
2. Remove the knockout for the 0.5 in. (13 mm) conduit from the enclosure and attach the conduit.
3. Feed the power wire into the enclosure.
4. When mounting on dry wall or other non-conductive surface, connect an earth ground to the earth-ground screw on the enclosure (Figure 47 on page 90).
5. Connect the ground wire from the 24 Vac transformer (not included) to the GND terminal (Figure 47 on page 90).
6. Connect the power wire to the 24V terminal.
7. Replace the cover of the enclosure.

Figure 47. Power and ground terminals



**Note:**

If a power transformer must be shared between EX-2 modules (an example would be at the FSCS), the +VA rating on output is 0.6 VA. This is enough to run any LED or sonalant provided on the FSCS. A maximum of 10 VA would be available to run other items. (All LEDs and sonic alerts are On during the LED test.)

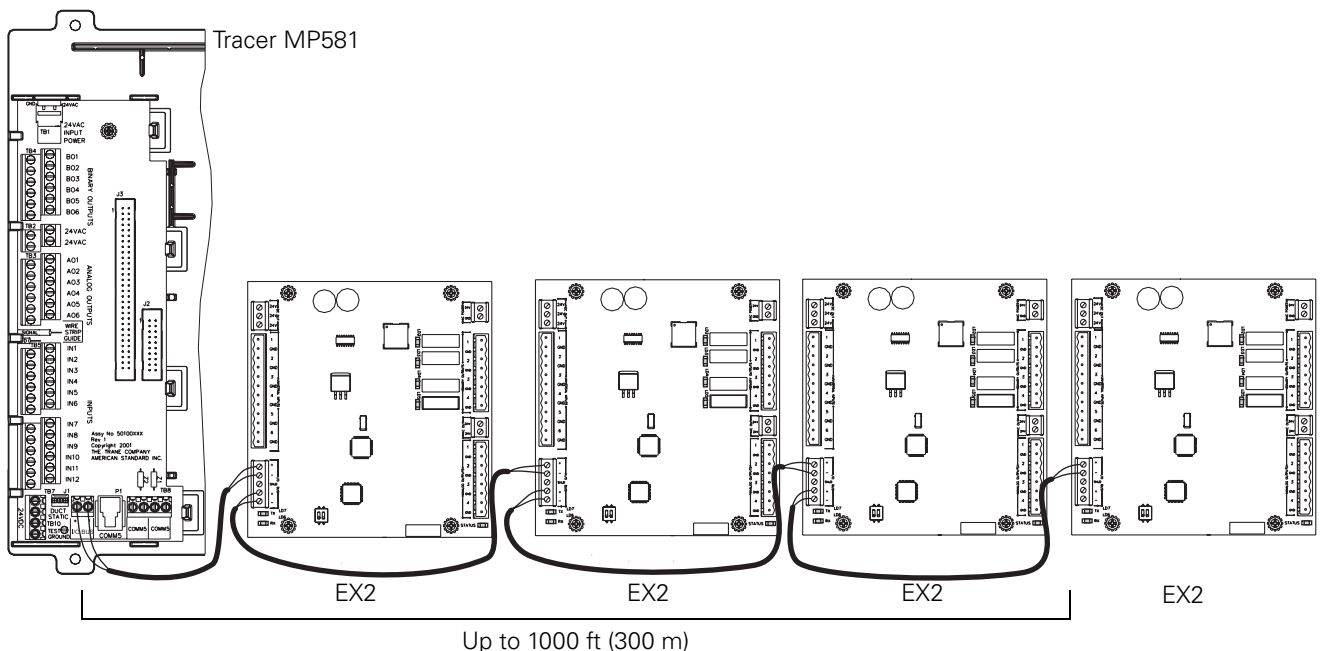
## I/O bus wiring

The EX2 communicates with the Tracer MP581 and up to three other EX2 modules on an IEEE-485 link. This link must be a daisy chain. Typically, the Tracer MP581 is at one end of the daisy chain, but any device can be at the ends of the link (Figure 48 and Figure 49 on page 92).

Wiring for the I/O bus must meet the following requirements:

- All wiring must be in accordance with the National Electrical Code and local codes.
- Recommended wire is low-capacitance, 22-gauge, Level 4, unshielded, twisted-pair. Existing sites that have already been wired with low-capacitance, 18-gauge, shielded, twisted pair with stranded, tinned-copper conductors (Trane-approved, purple-jacketed wire) don't have to be rewired. This shielded wire will work if properly terminated.
- Total I/O wiring length cannot exceed 1000 ft (300 m).
- At the first three modules, splice the shield with the shield from the next section of communication-link wiring, and tape the shield to prevent any connection to ground. At the final module on the end of the daisy chain, terminate the shield as shown in Figure 48. Note that you can use one, two, three, or four EX2 modules with each Tracer MP581.

**Figure 48. I/O bus wiring example 1**



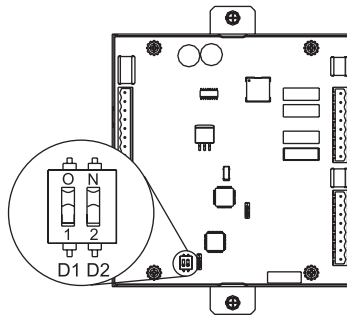




## Setting the I/O bus addresses

Each EX2 on the link with the Tracer MP581 must have a unique address. Configure the address using the DIP switches on the EX2 circuit board (Figure 50). Table 23 shows the DIP switch settings for expansion modules 1 through 4.

**Figure 50. DIP switch on board**



**Table 23. EX2 DIP switch settings**

EX2 module	D1	D2
1	Off	Off
2	Off	On
3	On	Off
4	On	On

## Input/output terminal wiring

All input/output terminal wiring for the EX2 module must meet the following requirements:

- All wiring must be in accordance with the National Electrical Code and local codes.
- Use only 18 AWG twisted-pair wire with stranded, tinned-copper conductors.
- Binary output wiring must not exceed 20 ft (6.1 m) and must be in conduit.
- Binary input wiring must not exceed 20 ft (6.1 m) and must be in conduit.
- Analog and 24 Vdc output wiring distances depend on the specifications of the receiving unit. Use shielding for analog and 24 Vdc outputs.
- Do not run input/output wires in the same wire bundle with ac-power wires.

## Chapter 6 Installing the EX2 expansion module

The EX2 module has four binary outputs, four analog outputs, and six universal inputs.

### Universal inputs

Each of the six universal inputs may be configured as binary.

### Binary outputs

The four binary outputs are form A (SPST) relay outputs. These relays are not dry contacts; they switch 24 Vac. A pilot relay is required for any application using dry contacts. Relays connected to the binary outputs on the EX2 cannot exceed 6 VA or 0.25 A current draw at 24 Vac.

### Analog outputs (UUKL nondedicated only)

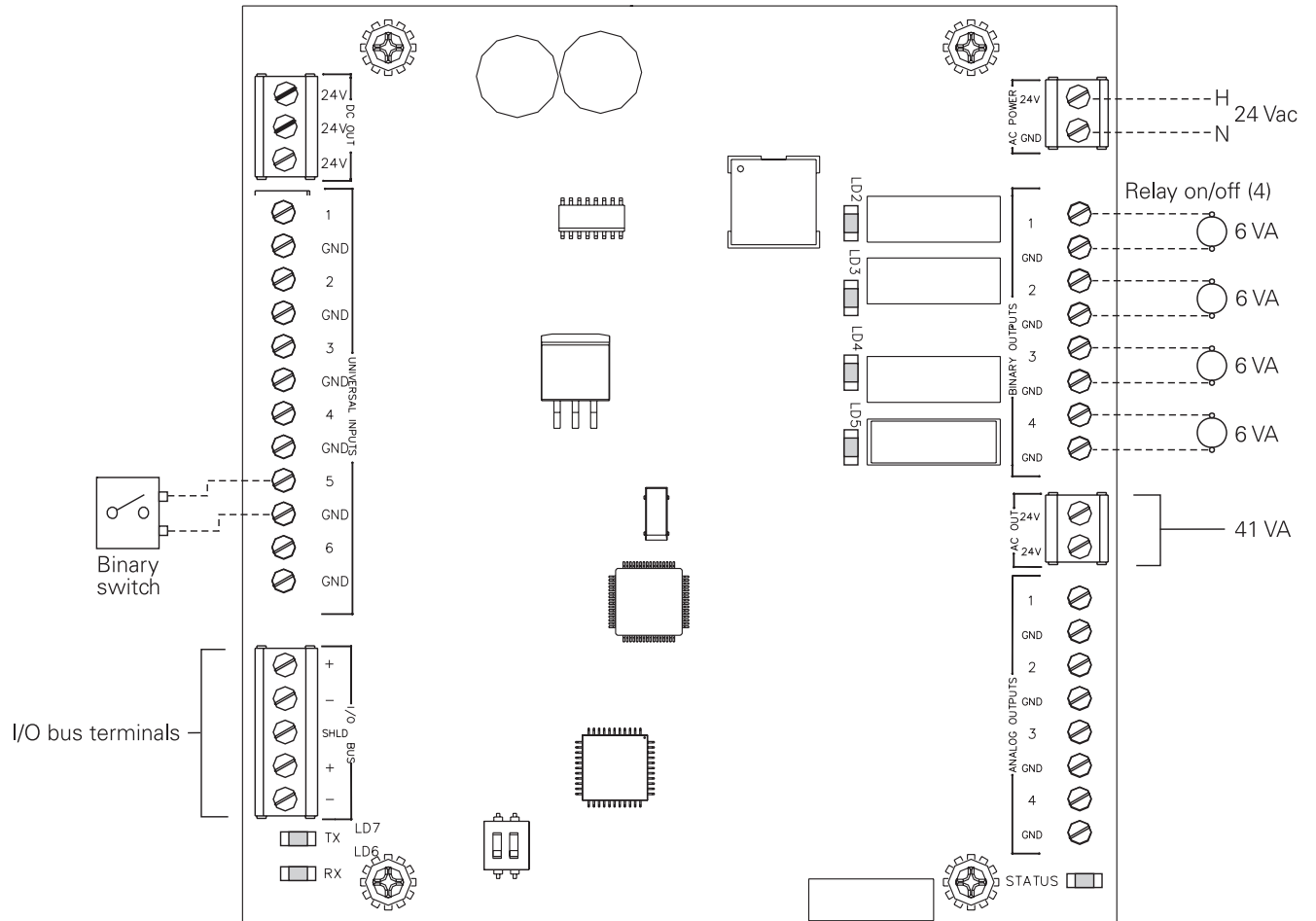
Each of the four analog outputs may be configured as either of the following:

- 0–10 Vdc
- 0–20 mA

## Analog output and universal input setup

Configure each analog output and universal input using a LonTalk service tool, such as Trane's Rover service tool. The service tool requires the Tracer MP581 software plug-in to configure an EX2. EX2 modules receive their configuration information from the Tracer MP581 controller they communicate with. You can do online configuration with the Rover service tool, or you can do offline configuration with Rover Configuration Builder. In either case, the EX2 modules will not receive their configuration until they are communicating with a configured Tracer MP581 controller.

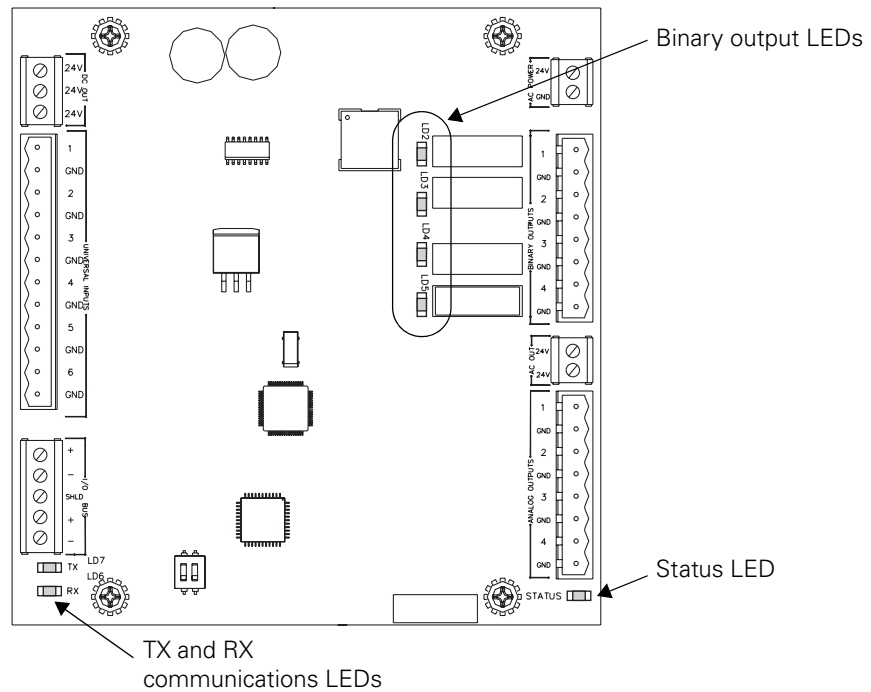
The inputs are factory configured to be not used. Analog outputs are configured for voltage. Figure 51 on page 95 shows how to wire some common sensor types and output devices.

**Figure 51. Typical input/output terminal wiring diagram for the EX2 expansion module**


## Interpreting EX2 LEDs

The information in this section will help you interpret LED activity on the EX2 expansion module. Figure 52 shows the location of each LED.

**Figure 52. LED locations on the EX2**



### Binary output LEDs

The LEDs labeled LD2 through LD5 indicate the status of the four binary outputs. Table 24 describes binary output LED activity.

**Note:**

Each binary output LED reflects the status of the output relay on the circuit board. It may or may not reflect the status of the equipment the binary output is controlling. Field wiring determines whether the state of the binary output LED also applies to the status of the end device. Table 24 describes the LED states.

**Table 24. Binary output LEDs**

LED activity	Explanation
LED is on continuously	The relay output is energized.
LED is off continuously	The relay output is de-energized or there is no power to the board.

## Status LED

The Status LED on the EX2 module operates differently from the status LED on LonTalk devices. Table 25 describes EX2 Status LED activity.

**Table 25. Status LED**

LED activity	Explanation
LED is on continuously	Power is on and the unit is operating normally.
LED blinks twice	The EX2 has not received its configuration from the Tracer MP580/581. Use the Rover service tool to make sure that the Tracer MP580/581 is correctly configured for use with the EX2 module. Check the I/O bus wiring.
LED blinks once	The EX2 is not communicating on the I/O bus. Check the communications LEDs described in Table 26 for more information.
LED is off continuously	Either the power is off or the controller has malfunctioned.

## Communications LEDs

The LEDs labeled TX and RX indicate the communication status of the EX2 module. Table 26 describes the LED activity.

**Table 26. Communications LEDs**

LED activity	Explanation
Both LEDs blink regularly	The EX2 is communicating with the Tracer MP580/581 on the I/O bus. (If the LEDs blink normally but the EX2 is not working properly, make sure that I/O bus addresses are not duplicated.)
Both LEDs are off continuously	The EX2 is not communicating on the I/O bus. Either the I/O bus wiring is faulty or the Tracer MP580/581 has not been configured to use the EX2 module. Use the Rover service tool to configure the Tracer MP580/581 for use with the EX2 module.
RX LED blinks, TX LED is off	The EX2 is receiving communications from the Tracer MP581 (either for itself or another EX2) but cannot send communications. Either the module is not configured in the Tracer MP580/581 or its I/O bus address is incorrect. Use the Rover service tool to configure the Tracer MP580/581 for use with the EX2 module. Make sure the DIP switches are set for the correct I/O bus address ("Setting the I/O bus addresses" on page 93).
RX LED is on continuously, TX LED is off	Polarity is reversed on the I/O bus wiring. Swap the wires at the plus (+) and minus (-) I/O bus screw terminals on the EX2 module.



***Chapter 6 Installing the EX2 expansion module***

## Chapter 7

# Programming

---

Programming occurs after hardware installation is complete. The smoke control system must be programmed for automatic response, weekly self-testing, end-process verification, and response to manual FSCS commands.

## Response times

Time response requirements must be kept in mind when programming. They are give in Table 27.

**Table 27. Time response requirements**

Response time	Process
10 seconds	(UL 864: 49.2.a) The maximum time allowed from when an activation signal is received until a fire or smoke safety function is initiated. An activation signal could be from the FACP of the FSCS.
15 seconds	The maximum time allowed between a feedback signal activation and an FSCS panel indication (either audio or LED). A feedback signal will typically be a binary value, either hard-wired or communicated.
60 seconds	(UL 864: 49.2.c) Fan operation proof of desired state, either on or off.
75 seconds	(UL 864: 49.2.c) Damper position proof of desired position, either open or closed.
200 seconds	(UL 864: 49.2.b) The maximum time allowed between determination of a failure state of critical equipment or process and notification of that failure. A failure state could include communication failures or equipment problems such as a fan not starting as commanded.

The 10 second time limit mentioned in Table 27 controls how fast Tracer Graphical Programming (TGP) programs can be run. Suggested program rates are 2 seconds for communication watchdogs and 4–5 seconds for control programs.

In general, the BCU cannot pass information faster than every 5 seconds. This is the fastest a CPL routine can run. A BCU is included to collect system events, such as communication failure, and allow a user a remote connection to the system for status.

## Operational priority

(UL 864: 49.10)

The following descending order of priority shall be followed in processing smoke-control commands:

1. Manual activation and deactivation commands issued at the FSCS.
2. Manual activation and deactivation commands at other than the FSCS.
3. Initial automatically actuated smoke-control sequence. The system does not need to override any manual activation or de-activation functions in place prior to the automatic control sequence.
4. All other manual or automatic operation used for normal building operation.

For programming purposes, the priority list in descending order is:

1. Any manual control of dampers, fans, and smoke control panel control.
2. Automatic smoke control system reaction.
3. System test processes such as normal HVAC control, lamp tests, or system self-tests.

All of the above priorities refer to performance, not annunciation. For instance, if a lamp test is running and a user overrides one of the dampers, the annunciation (LED) may not change while the actuator moves. In this case, the lamp test is not affecting system performance, just annunciation. However, if a system self-test is running, either a smoke alarm trigger or manual override will end the self-test. More detail is shown in Table 28 on page 101.



**Table 28. Operational priority**

		Current state of system				
		Manual override	Automatic smoke alarm	System self-test	Panel lamp test	HVAC (nondedicated)
Next state of system	Manual override	N/A	Actuator is overridden.	System self-test ends.	Panel lamp test can continue.	Actuator is overridden.
	Automatic smoke alarm	Affects all non-overridden actuators.	N/A	System self-test ends.	Panel lamp test ends.	HVAC system operation is completely suspended. Only smoke purge operation is allowed.
	System self-test	System self-test is not allowed to start.	System self-test is not allowed to start.	N/A	Allowed. No change.	System self-test not used.
	Panel lamp test	Panel lamp test is allowed to start.	Panel lamp test is not allowed to start.	Panel lamp test is allowed to start.	N/A	Panel lamp test is allowed to start.
	HVAC (nondedicated)	HVAC system running, but overridden actuator will be affected.	HVAC operation is not allowed to start.	System self-test not used.	HVAC operation continues.	N/A

## Subsequent alarms

(UL 864: 49.8)

When multiple input signals are received from more than one smoke zone to initiate different automatic smoke-control sequence(s), the smoke-control system shall continue automatic operation in the mode determined by the first signal received.

Once a floor-based smoke alarm is activated, the system will react as if that is the only alarm and will ignore all subsequent alarms, The supply, return and stair shaft smoke alarms are still allowed to affect the supply, return and stair shaft supply fans. Any reaction can be overridden at the smoke control panel.

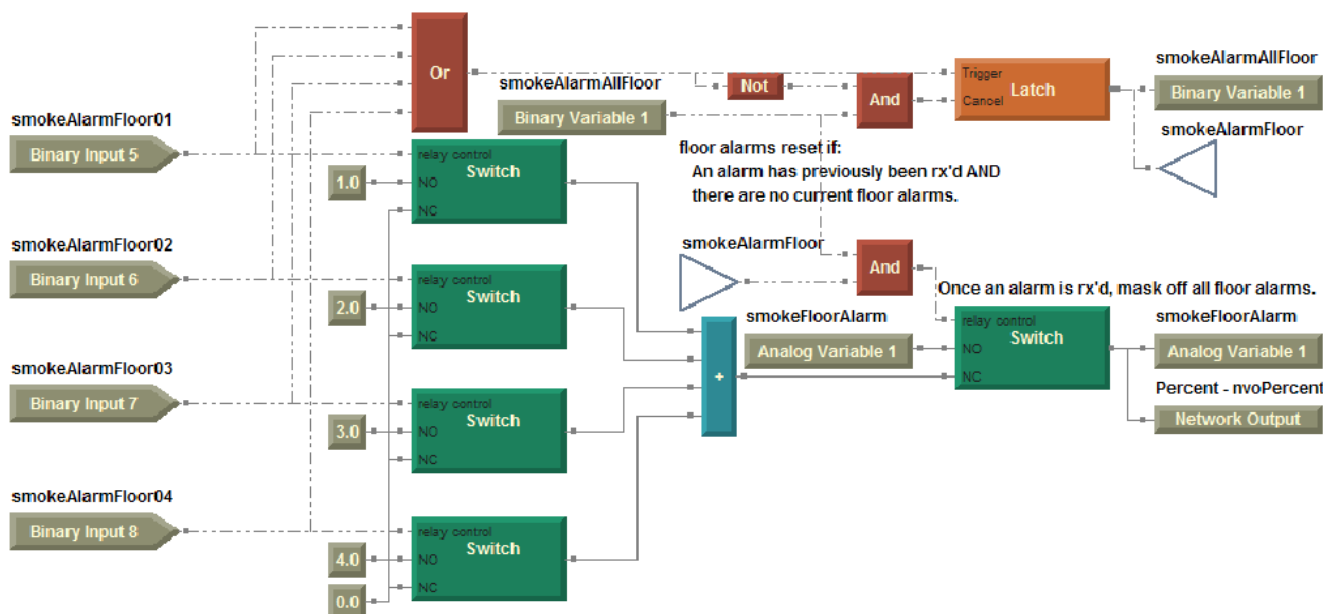
To ignore all subsequent floor alarms, the program fragment in Figure 53 on page 102 has been tested and works correctly. Once an alarm is triggered by any floor-based smoke alarm, it will be the only smoke alarm reaction allowed. When the first alarm is received, it triggers two events; it writes the floor of the smoke alarm to analog variable 1 and sets a binary variable to hold the output at that value. That binary variable is held until all alarms are cleared by the fire smoke control system.

The wireless connector, smokeAlarmFloor, is used for the following two reasons:

- Because smokeAlarmFloor clears the floor alarms value one program execution sooner than when using just the binary variable, smokeAlarmAllFloor
- To send a smoke alarm to any floor (see Figure 54 on page 103).

The relevant floor smoke alarm is communicated to the smoke control panel and mechanical system via a custom binding.

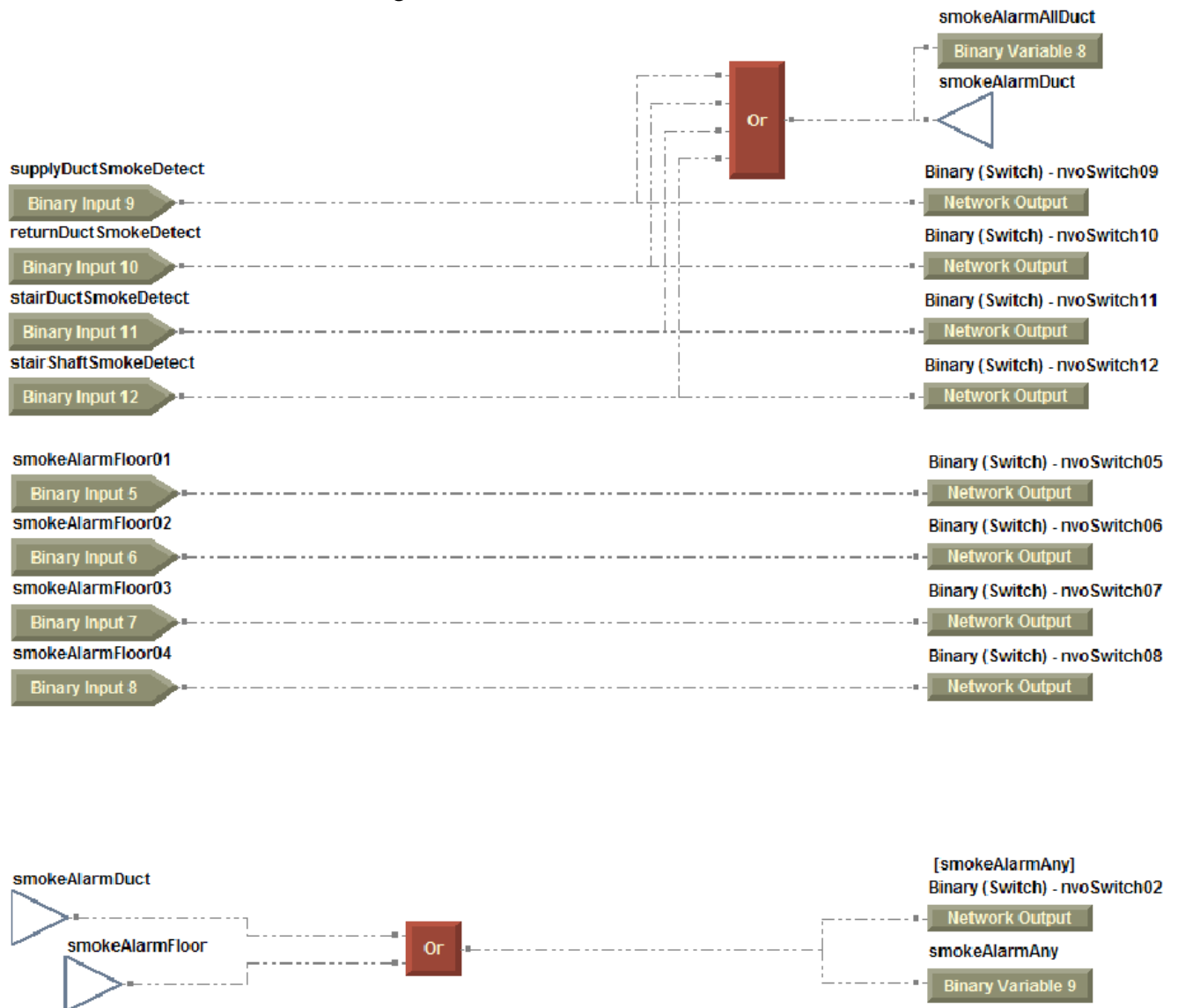
**Figure 53. Subsequent alarms—First reaction**



## Smoke alarm annunciation

Systems serving two or more zones shall visually identify the zone of origin of the status change (UL-864: 33.2.1). The visual annunciation shall be capable of displaying all zones having a status change (UL-864: 33.2.2). These requirements are interpreted to mean that *any* smoke zone alarm is annunciated by the smoke control panel regardless of alarm order. If any smoke zone alarm is triggered, the alarm state is sent to MP580 controllers that interface with and control the smoke control panel. Figure 54 illustrates a means of programming to meet requirements 33.2.1 and 33.2.2. An additional value, smokeAlarmAny, is broadcast as a means to provide information for priority-based decisions (see Table 28 on page 101).

Figure 54. Smoke alarm annunciation



## **Chapter 7 Programming**

From requirements 33.2.1 and 33.2.2, we can see that there is a decoupling between annunciation and reaction. The series of network variables shown in Figure 54, nvoSwitch05 through nvoSwitch12, are used to directly control the smoke alarm LEDs on the FSCP. For example, a smoke alarm for floor 1 is received. The mechanical system reacts by pressurizing floor 2 and exhausting floor 1. Following that, floor 2 goes into smoke alarm. The alarm needs to be annunciated even though the mechanical system does not react. In this case, nvoSwitch06 passes the smoke alarm state to MP580-3 by using a custom binding. At MP580-3, the binary output that controls the floor 2 smoke alarm LED is turned on.

## Weekly self-test of dedicated systems

(UL-864: 49.7)

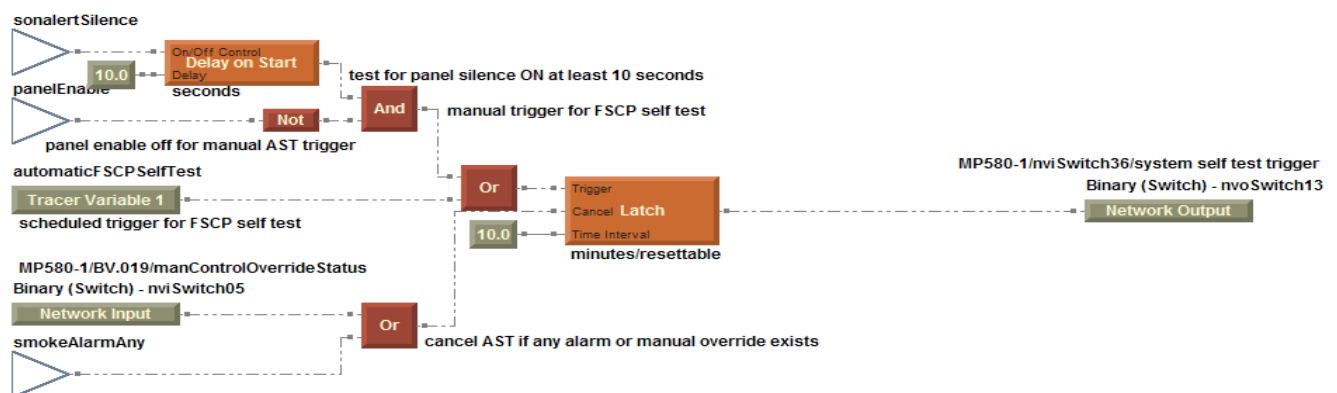
Dedicated smoke-control systems shall employ a weekly automatic self-test (AST). The AST automatically commands activation of each associated function. An audible and visual trouble signal shall be annunciated at the FSCP, identifying any function that fails to operate within the required time period. Nondedicated smoke control systems do not require a scheduled AST.

Dedicated smoke control system equipment must be programmed to automatically test itself on a weekly basis. The tests ensure that the system will operate if needed. Nondedicated smoke control system mechanical equipment is assumed to be tested by the working HVAC system.

Two approaches can be used to test the mechanical function of the system: either test each damper or fan as if it is being overridden from the smoke control panel, or test the reaction to each floor alarm. The first technique, which is the most comprehensive and requires the least programming, will be discussed. In either case, a failure must be annunciated at the smoke control panel both visually and audibly. It is acceptable to use the Trouble LED, the relevant failure LED, and the interior audio alert.

An AST can be triggered either from a BMTX BCU or manually at the smoke control panel. Figure 55 shows a program fragment that triggers the AST. The scheduled trigger uses a Tracer Summit controlled binary variable. To manually trigger the AST, the user disables the smoke control panel and silences the audio alarms for 15 to 20 seconds. The AST signal is then sent to the mechanical system control to start the self-test process. Note that in the program fragment shown in Figure 55, that any smoke alarm will disable the AST.

**Figure 55. Triggering the automatic self-test (AST)**

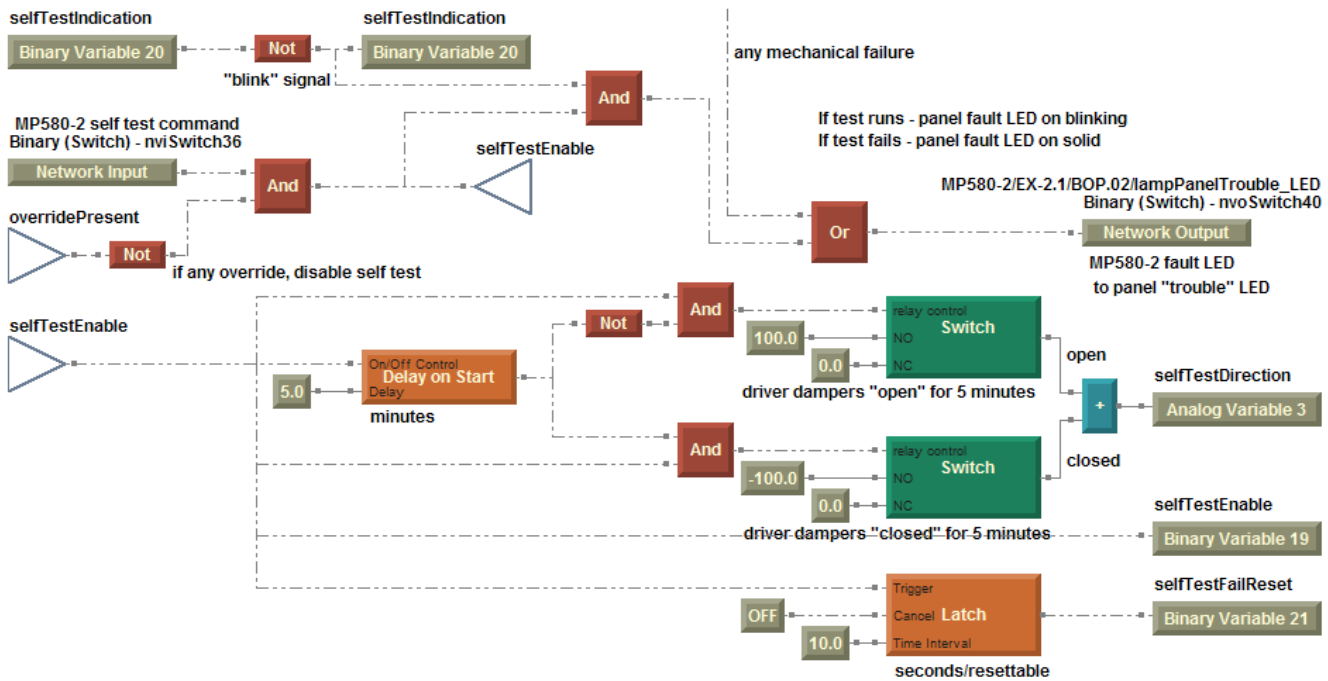


At the receiving end of the AST signal is the mechanical system which is under test. The automatic self-test is 10 minutes long. The outputs of the program are system fault, damper direction (Open/Close) or fan state

(On/Off), self-test enable, and self-test reset. Damper direction and fan state are set to Open/On for 5 minutes then Close/Off for 5 minutes. There is also a “blink” function built into the program fragment. Whenever the AST is enabled and there are no mechanical faults, the trouble LED will blink.

Resetting mechanical system faults is somewhat ambiguous. If the fault occurs in the smoke alarm mode, the alarm can be reset when the request stops. However, an AST-based fault must be annunciated and held until the fault is repaired. It is not clear what faults are allowed to clear the alarm, as there is no “reset fault” function available on the smoke control panel. Discussion with UL revealed that it is acceptable to annunciate the alarm until the next AST. Thus, the selfTestFailReset binary variable, shown in Figure 56, is used to reset all AST triggered faults.

**Figure 56. Mechanical reactions during AST**



[Figure 57 needs to be introduced.]

**Figure 57. ast overridesense 3-13-2006**

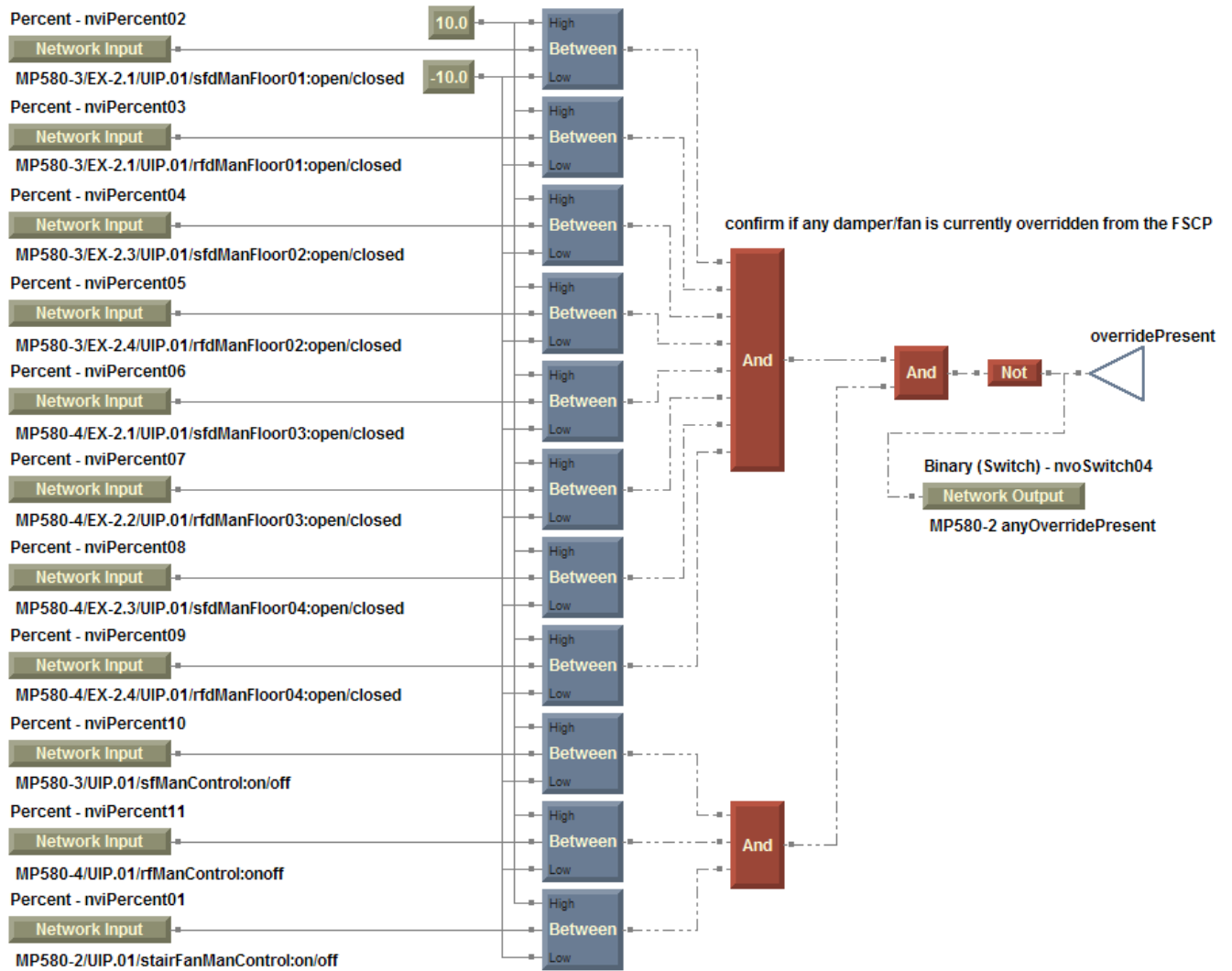
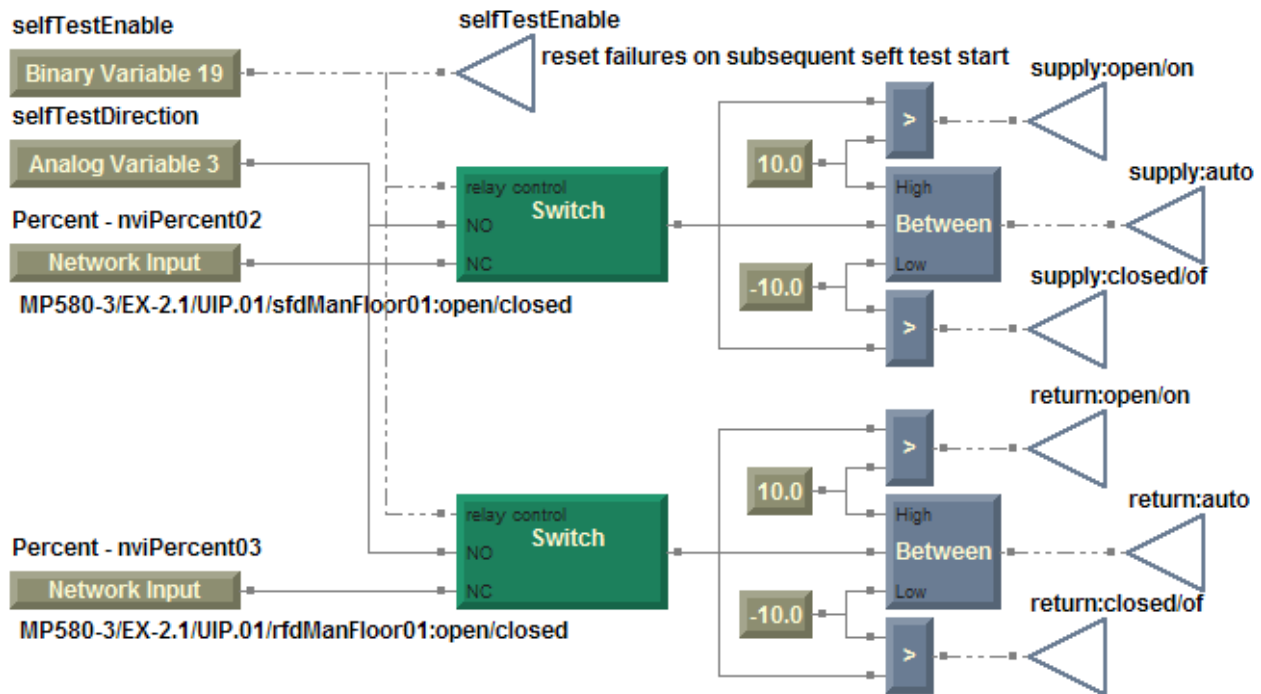


Figure 58 illustrates how adding self-testing to the system affects programming for damper control on each floor. The self-test request becomes another source of damper/fan control, along with automatic and manual override self-tests. The existence of the self-test signal is indicated by the binary variable, “selfTestEnable”. Once self-testing is enabled, dampers and fans become controlled by a direction variable. The variables, selfTestEnable and selfTestDirection, along with accompanying switch logic are not necessary in non-dedicated systems.

**Figure 58. Effect of AST on damper control**





## End process verification

End process verification confirms that a device responded to an operation command. End process verification programming consists of:

- Programming the system to test binary input points for responses to commands sent to output points
- Setting a counter to provide a time delay that allows the system time to respond before setting a fail flag
- Setting a fail flag if the counter times out
- Programming the system to send a fail flag to Tracer MP581s controlling the FSCS, which results in the FSCS turning on a fail light

Figure 59 shows an example of TGP used to determine a status of the outdoor air, return air, and exhaust air dampers. Each damper position status is compared to the relevant damper position request and a normal/fail state flag is derived. This segment will trigger an alarm event and send a fail flag to the Tracer MP581 that interfaces with the FSCS panel. A mechanical system reaction to the failure is not necessary.

Based on Table 28 on page 101, the self-test needs to be overridden if either a smoke alarm is triggered or a manual override takes place.

**Figure 59. Sample TGP showing fail test technique**

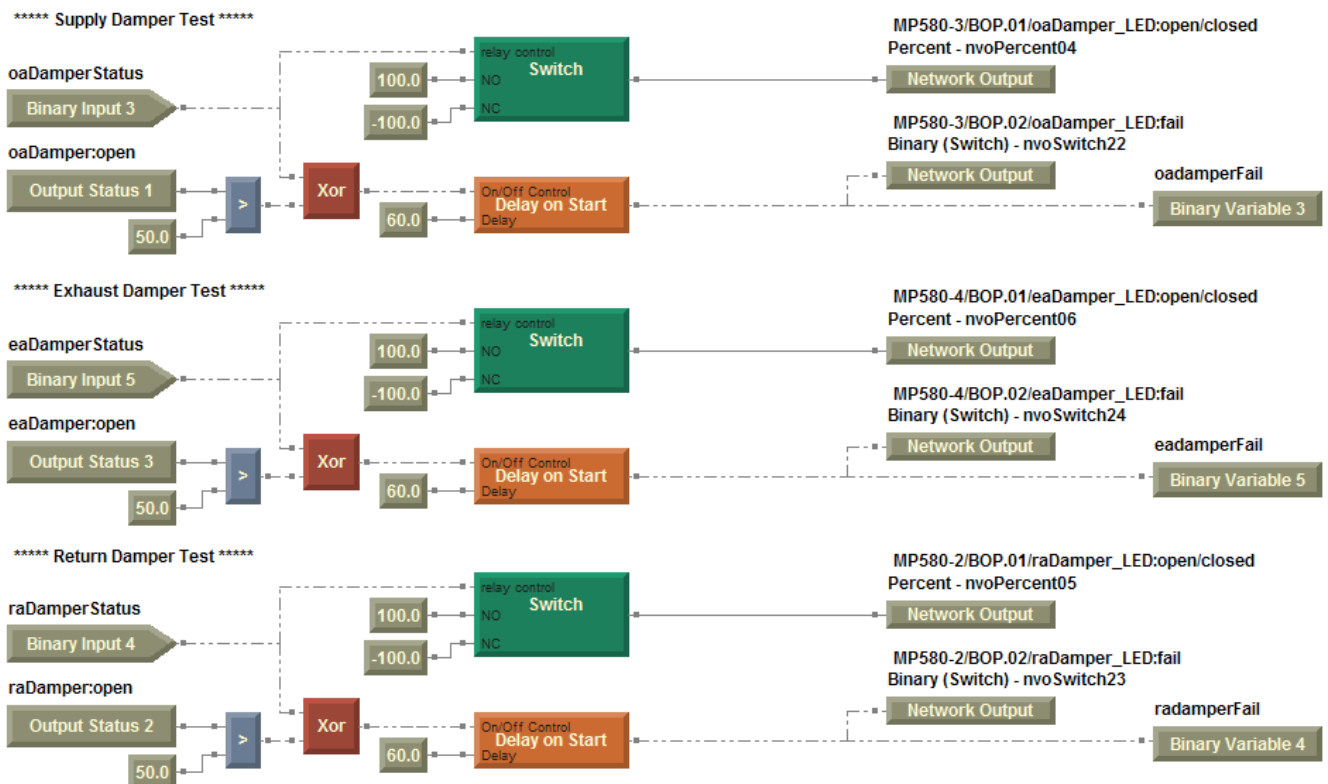
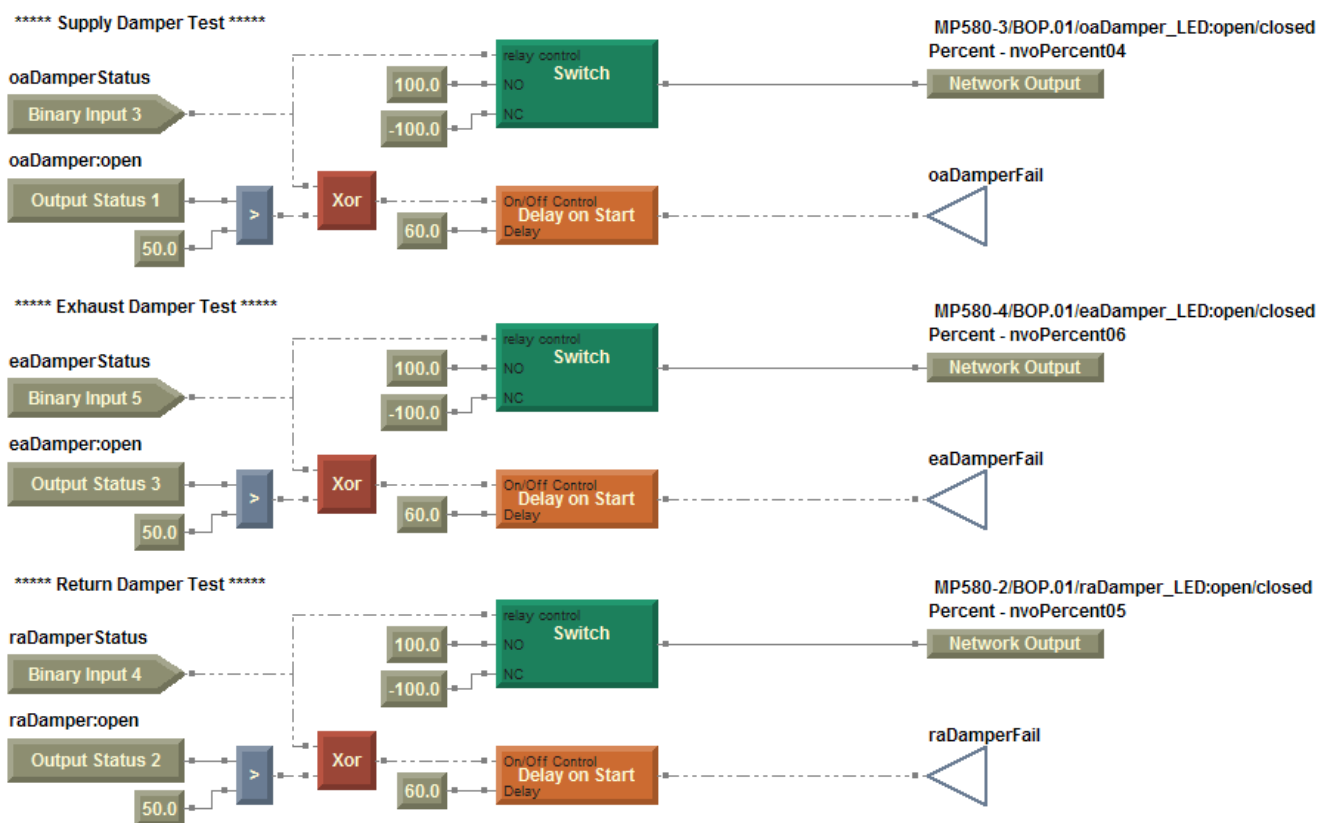
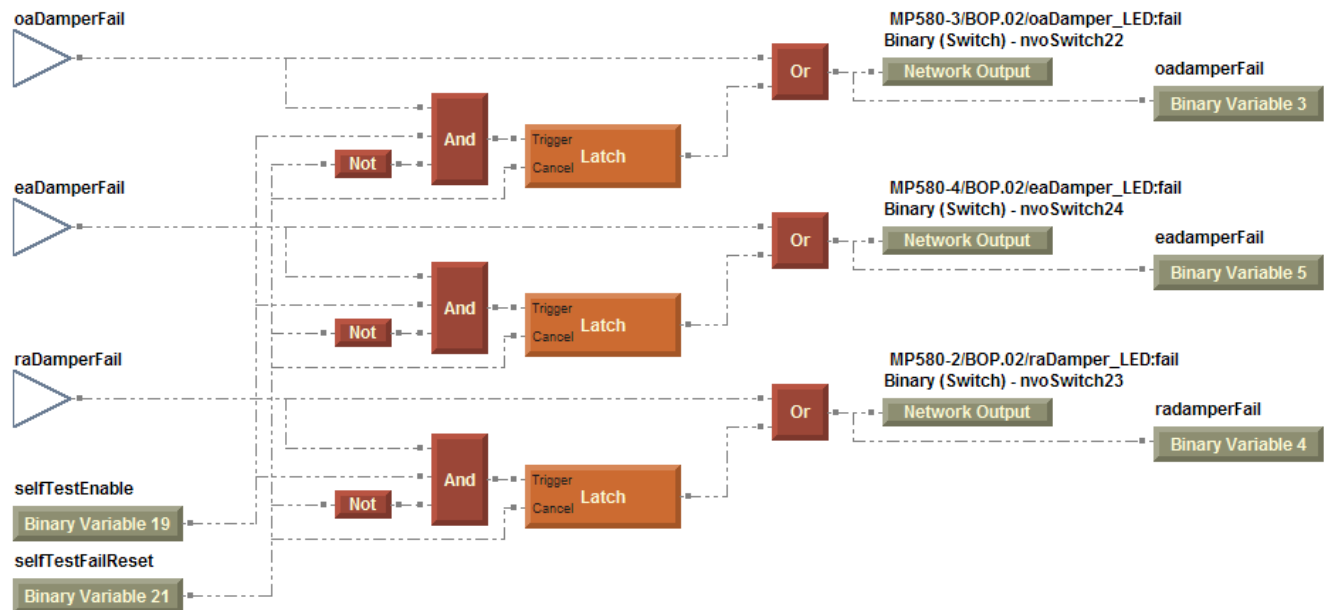


Figure 59 illustrates a basic actuator failure routine. Some changes are necessary when automatic self-testing is added to the program. The different ways of controlling an actuator have different means of resetting a failure. The failure reset is automatic if a failure is discovered during an automatic smoke alarm response or manual override from the smoke control panel. The failure indication is only maintained while there is a failure. On the other hand, the triggering of a system self-test, either scheduled or manual, will reset any failures discovered during a previous system self test. Figure 60 and Figure 61 on page 111 show the changes necessary to any dedicated system failure test routine. In either case, the connected BCU should be programmed to store the actuator failure in the alarm log.

Binary variable 21 goes true for a minimum of 10 seconds whenever a system self-test is triggered (see Figure 56 on page 106). This will reset any stored failures from a previous system self-test.

**Figure 60. ast actuator fail checka 3-13-06**



**Figure 61. ast actuator fail checkb 3-13-06**


## Communication watchdog

Since multiple Tracer MP581s are used to interface with the mechanical equipment and FACP and FSCS panels, checking communications between each MP581 and BCU is necessary. Three different communication systems are used: BCU to MP581 (auto-bind), MP581 to MP581 (custom bind), and MP581 to EX2. The BCU cannot determine communication status of custom bindings.

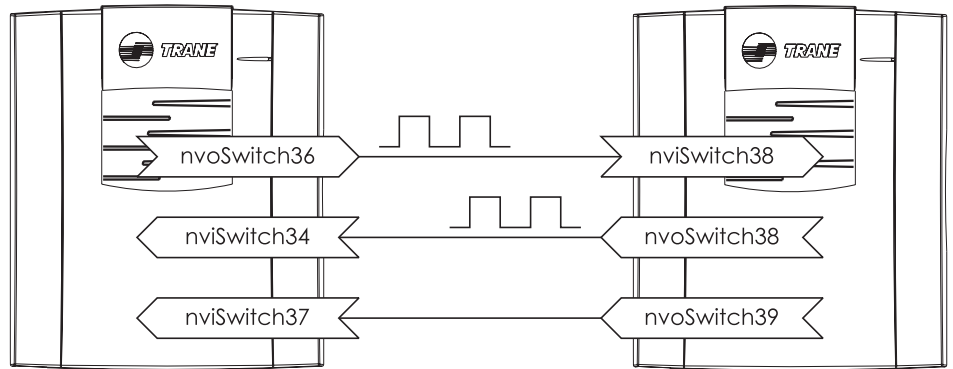
One Tracer MP581 should be chosen to be the communication watchdog. Otherwise, the number of watchdog timers and Tracer MP581 permutations may exceed binding limits.

Figure 62 on page 113 illustrates the communication watchdog relationship. Figure 63 and Figure 64 on page 113 are TGP examples of the transmitting and receiving units, respectively. From the point of view of the receiving MP581, this technique tests whether the central unit can transmit by using a custom binding. As long as the programmer chooses to test from both ends, this process will fully test the communication status of the MP581-to-MP581 system. Other communication status such as that of the I/O bus (EX2 modules) and BMTX BCU can also be transferred to the central MP581.

The basic watchdog method consists of sending an alternating signal from one MP581 to another MP581. A custom binding is necessary for the MP581-to-MP581 communication link. Although there are many ways to bind the two devices, for this example use MP581-2/nvoswitch36 to MP581-1/nviSwitch38. Whenever nviSwitch38 goes from false to true, a retriggerable latch block is triggered, holding its output state to true. When a number of stat changes are missed—typically three—an alarm event will be triggered at the BCU. It may be necessary to adjust the delay time of the latch block to avoid false communication alarms.

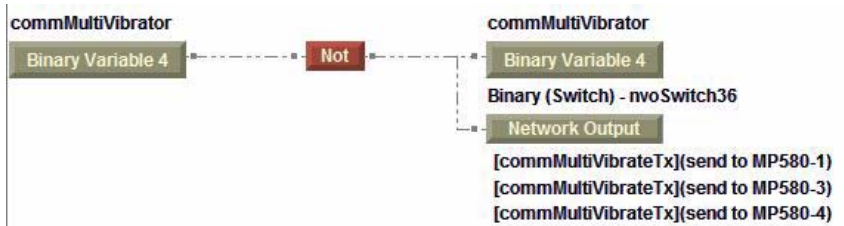
A response to communication status is necessary only if communication fails at any level. According to UL, a mechanical system reaction to communication loss is not necessary. Local requirements may require a mechanical reaction to communication loss.

**Figure 62. Watchdog communication relationship between a system MP581 and the central FSCP control MP581**



 = signal with a periodic change (watchdog)

**Figure 63. Sample TGP showing transmitting during watchdog communication process]**



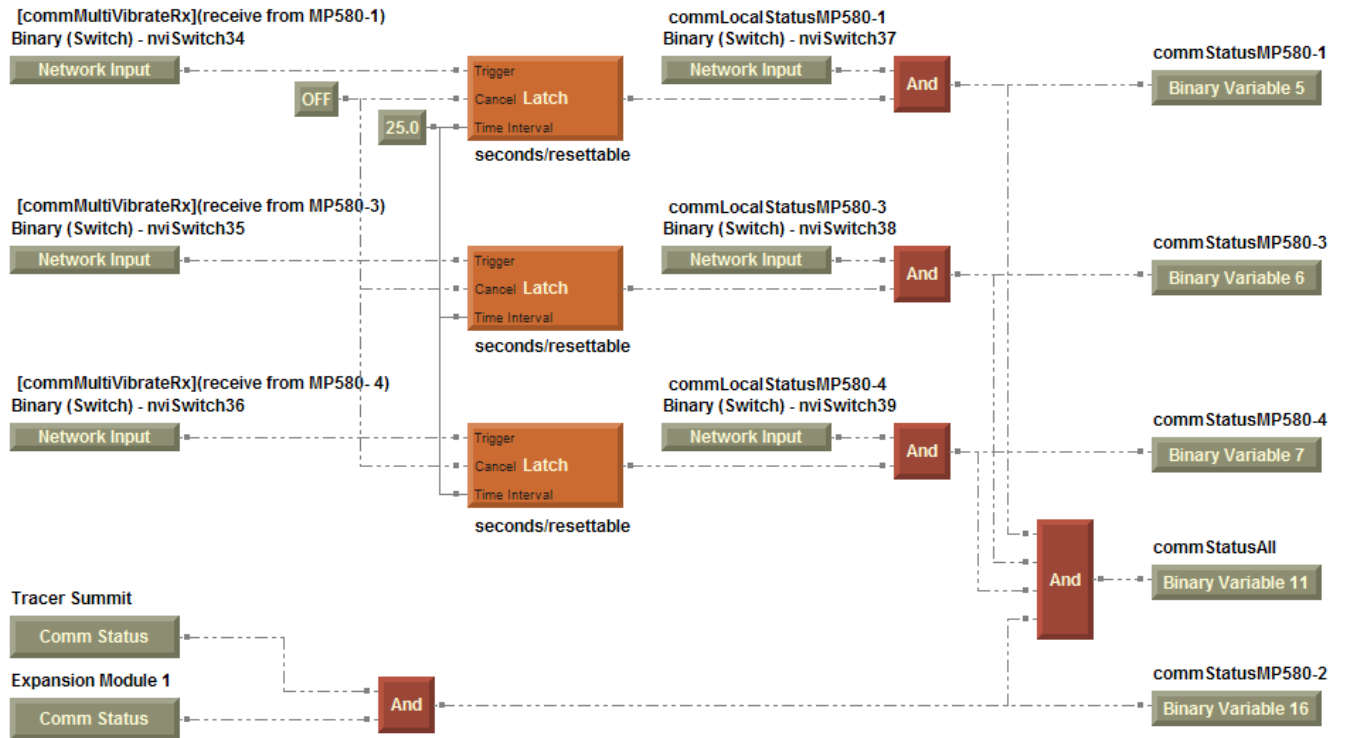
**Figure 64. Sample TGP showing watchdog signal receive process**



There are three communication signals used in the smoke control system: BCU to MP581, MP581 to MP581, and MP581 to EX-2. The status of all three communication types needs to be indicated at the smoke control panel. Each MP581 collects communication status information from the connected BCU and its associated EX-2 modules and transmits the status back to the smoke control panel MP581. A custom binding, MP580-1/nvoSwitch39 to MP580-2/nviSwitch37, is used to send the collected status

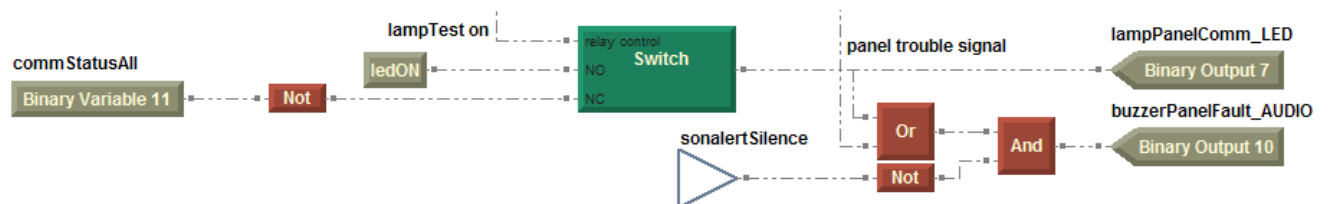


**Figure 66. Determining overall communication status for the system**



Finally, the FSCP Comm Fault LED is controlled. A sample TGP fragment is shown in Figure 67. The FSCP Comm Fault LED is also controlled by the lamp test function. If a lamp test is not currently running, the FSCP Comm Fault is controlled by the overall communication status of the system.

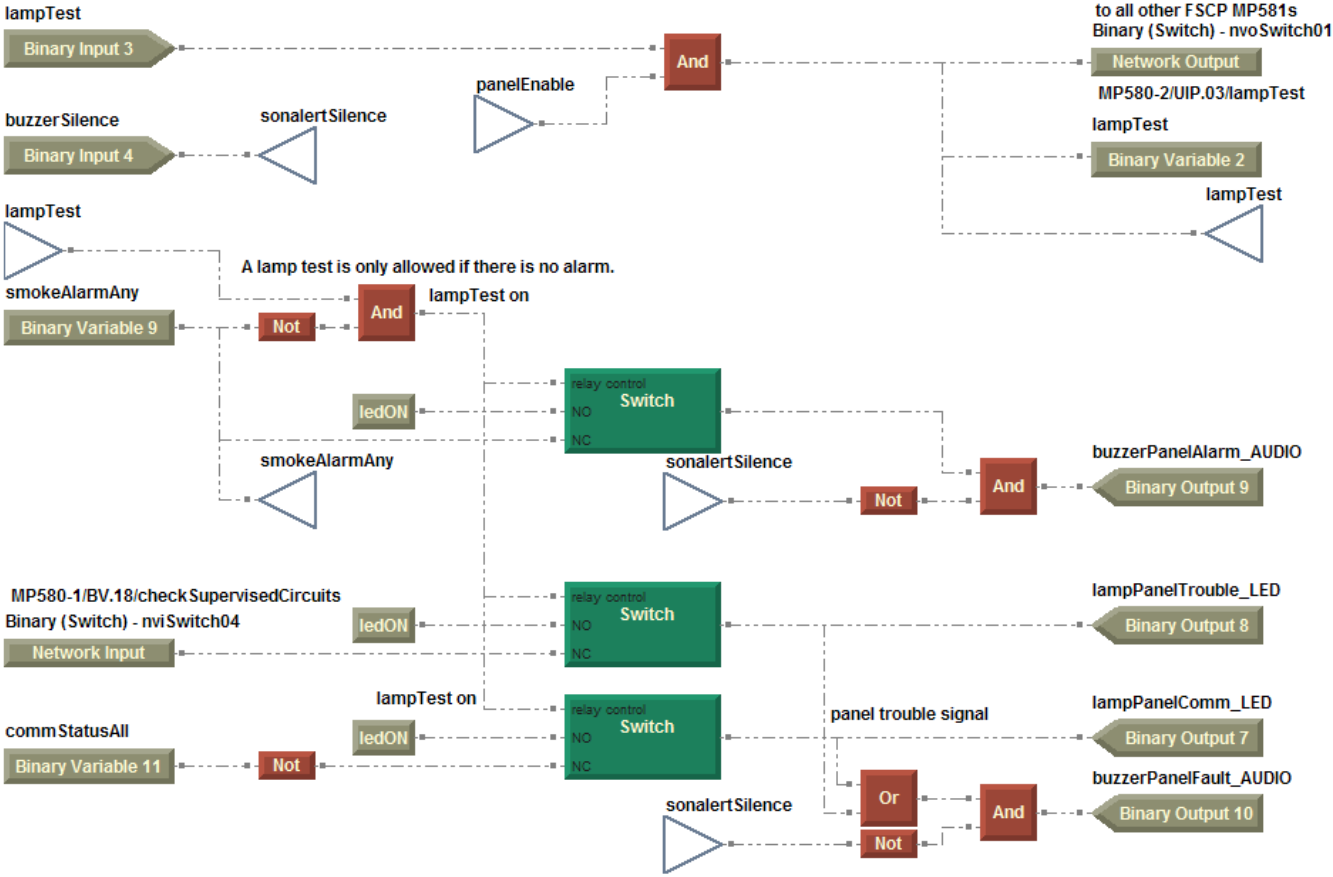
**Figure 67. Control of the FSCP Comm Fault LED**



# Lamp test and audio alarm silence

A lamp test must be performed for every FSCS panel. This test will cause all indicator lights to come on. However, an alarm takes precedence over the lamp test. Figure 68 shows a TGP program fragment that will enable a lamp test relevant to its own LEDs while broadcasting a lamp test request to other Tracer MP581s. An audible alarm test and silence routine are included.

Figure 68. Sample TGP showing lamp test and audio alarm silence routine



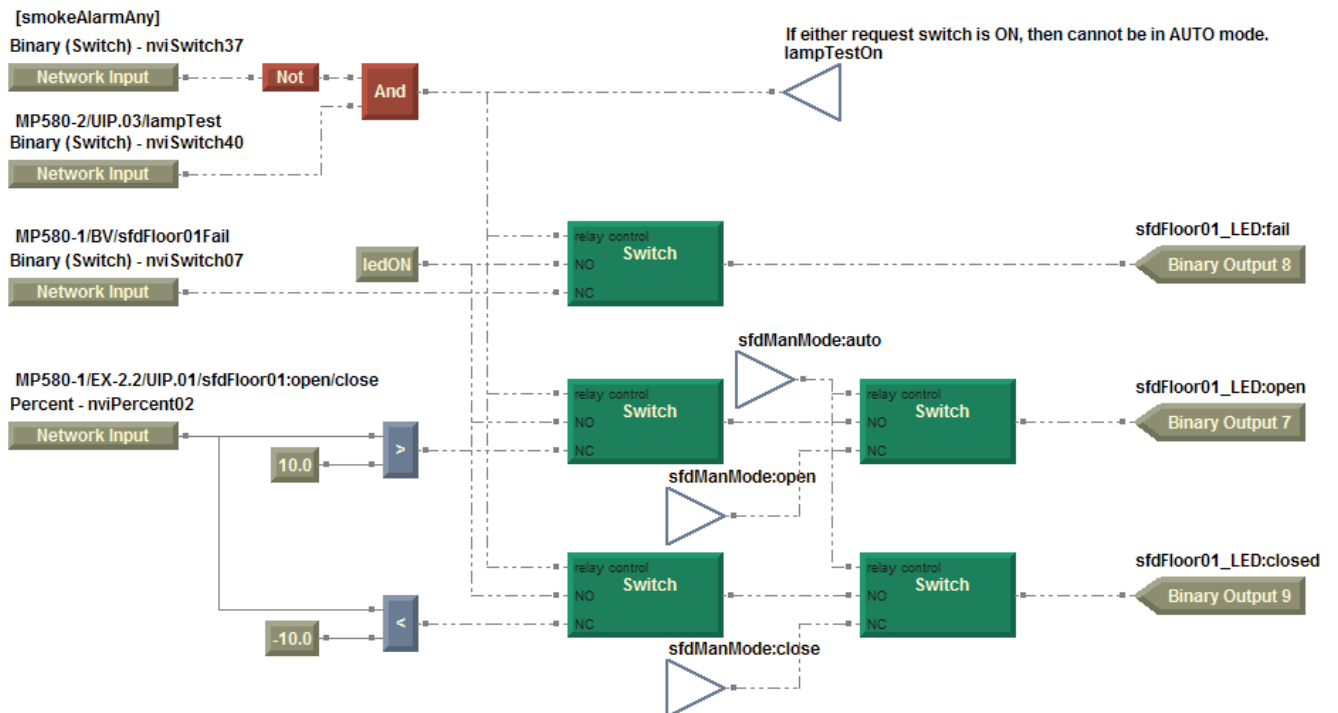


Triggering a lamp test affects all LEDs on the smoke control panel. Figure 69 shows an example of how to use the lamp test signal in combination with any smoke alarm information.

**Note:**

Note that the lamp test is not allowed to start or run if there is a smoke alarm.

**Figure 69. Example of lamp test controlling FSCP damper LEDs**



## Nondedicated smoke purge

(UL-864: 3.21.h)

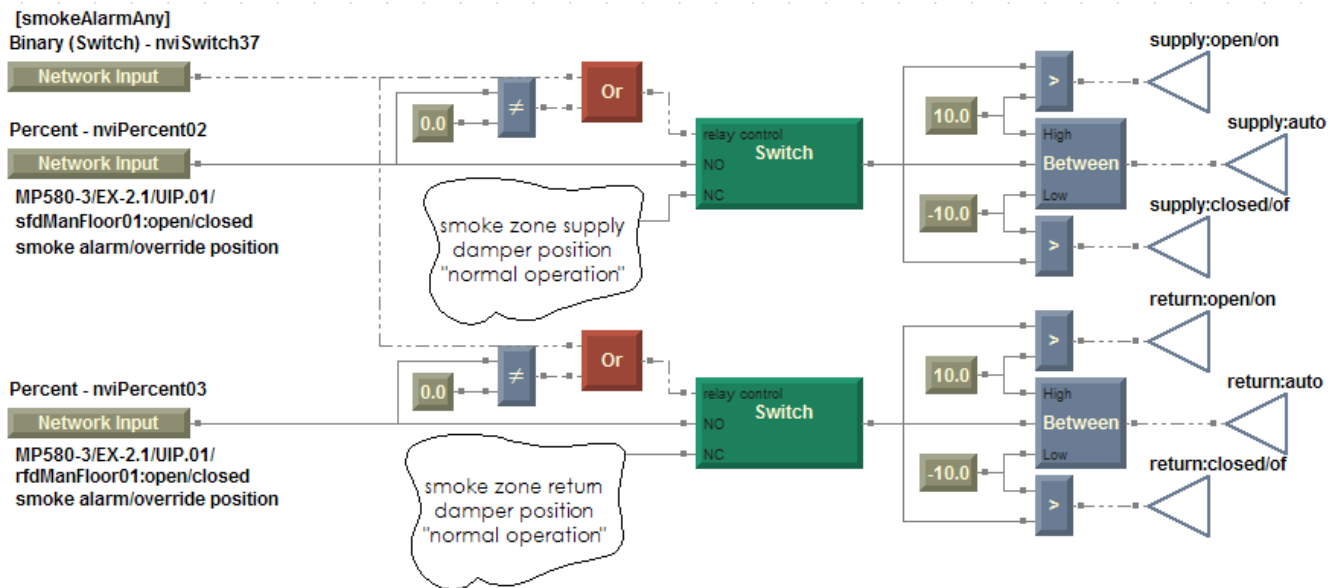
The term *nondedicated* refers to a system that provides the building's HVAC functioning under normal conditions and a smoke control objective during a fire alarm condition.

The main concern when designing a nondedicated system is for programming to ensure that, once a smoke alarm or FSCP override occurs, any component of the smoke control system is controlled solely by automatic smoke control or manual override commands. For details regarding priority, see Table 28 on page 101.

Figure 70 shows an example of programming for a nondedicated system to implement the priorities in Table 28. In this figure, the smoke control dampers for Floor 1 are controlled. The actuator position, either Open or Closed, will default to whatever the HVAC system commands. There are two states that will turn control over to either automatic smoke control or FSCP overrides:

- If the broadcast general smoke alarm is TRUE, or
- If the FSCP override switch is set to either Open or Closed.

**Figure 70. Implementing priorities for a nondedicated system: Controlling damper actuators**



## **Variable-air-volume system**

For variable-air-volume (VAV) systems, some form of duct pressure relief is required on each floor or in each smoke control zone. In smoke control mode, all return and supply fans will be set to their highest speed. If the VAV dampers are closed when this occurs, the duct pressure may be enough to damage the ductwork. To avoid this possibility, duct pressure relief dampers, either DDC or mechanically controlled, should be installed in the ductwork for each smoke control zone.

It should be noted that careful sizing of smoke control supply air damper and relief damper is necessary to use smoke purge and protect dampers.

## **Constant-volume system**

For constant-volume systems in smoke control mode return/exhaust dampers are open. Therefore, separate duct pressure relief is not required, but may be necessary on each floor or in each smoke control zone, as it is for VAV systems. Supply dampers should be sized such that any one damper can spill an adequate amount of air.

## **UL-tested programs**

This application guide showed only excerpts of UL-tested TGP programs. Programs in their entirety can be found and downloaded from the GCS Product Support Web site. These programs may or may not meet local smoke alarm requirements. In all cases, defer to local smoke control specifications.



**Chapter 7 Programming**

## Chapter 8

# Network variable bindings

---

## Overview

The LonTalk communications protocol allows data to be shared between devices (stand-alone or with a BAS) on a LonTalk network. This is called peer-to-peer communication. As an example of peer-to-peer communication, two or more devices serving the same space share data, such as a temperature reading, without having to pass the data through a BAS.

Network variables are used to share data between devices. The method used to direct data from one device to another is called network variable binding, or just binding. A network variable output from one device is bound to a network variable input on another device. An output variable from one device can be bound to input variables on many other devices.

## Binding network variables

Each network variable is a standard type. This standard type is referred to as a standard network variable type (SNVT). To bind two variables together they must be the same SNVT. For example, an output of type SNVT\_temp\_p can only be bound to an input of type SNVT\_temp\_p. For more information about SNVTs, see the LonMark™ Web site ([www.lonmark.org](http://www.lonmark.org)). From that Web site you can download the official list of SNVTs.

### IMPORTANT

**Only LonTalk devices can use network variable binding. Devices on other communications links do not have this capability.**

BAS communications typically do not require the use of network variable binding because a Tracer Summit BCU will automatically bind to the proper data in a device. However, communications speed may be increased between two devices by binding their data rather than having the BAS read the information from one device and then broadcast it to another.

Use the Rover service tool to create bindings. (See the *Rover Operation and Programming* guide, EMTX-SVX01E-EN.)

## Tracer MP580/581 bindings

This section discusses which network variables will be necessary to achieve UUKL time performance requirements. Only “generic” network variables, which are neither Space Comfort Controller (SCC) or Discharge Air Controller (DAC), are necessary. Use of generic variables does not affect either BCU auto-bound network variables or SCC or DAC based network variables.

### Receiving data

A network variable input (nvi) *receives* data from other devices on the LonTalk network. The generic network variable inputs, nviSwitch and nviPercent, that are commonly used in Tracer MP580/581 bindings are shown in Table 29.

**Table 29. Tracer MP580/581 generic network variable inputs**

Variable name	SNVT	Data type	Description
nviSwitch01 ... nviSwitch40	SNVT_switch	Binary	Bind to these 40 network variable inputs to communicate binary values to the device.
nviPercent01 ... nviPercent20	SNVT_lev_percent	Analog	Bind to these 20 network variable inputs to communicate levels in percent to the device. The valid range is from -163.84% to 163.83% with a resolution of 0.005%.

### Sending data

A network variable output (nvo) *sends* data to other devices on the LonTalk network. The generic network variable outputs, nvoSwitch and nvoPercent, that are commonly used in Tracer MP580/581 bindings are shown in Table 30.

**Table 30. Tracer MP580/581 generic network variable outputs**

Variable name	SNVT	Data type	Description
nvoSwitch01 ... nvoSwitch40	SNVT_switch	Binary	These 40 network variable outputs communicate binary values to other devices.
nvoPercent01 ... nvoPercent20	SNVT_lev_percent	Analog	These 20 network variable outputs communicate levels in percent to other devices. The valid range is from -163.84% to 163.83% with a resolution of 0.005%.

### Heartbeated network variables

All necessary information can be sent using nvoSwitch (SNVT\_switch) and nvoPercent (SNVT\_lev\_percent), which are “heartbeated” variables. All necessary information can be received using nviSwitch (SNVT\_switch) and nviPercent (SNVT\_lev\_percent). Heartbeated variables are a means of indicating freshness of information and/or quality of the communication link. For more information regarding heartbeating, see “Understanding bindings” on page 130.

## Custom bindings

A distinction is made between FSCP and mechanical system control in this section. While smoke control panel processing is predictable, mechanical system processing (actuators, feedback validation) is unknown. It is limited to approximately five smoke control zones based on the UUKL-approved smoke control panel. Because the number and application of each MP581 and EX2 modules is unknown, the mechanical system will be represented as a “cloud.”

The recommended smoke control system design is to have one MP580/581 assigned as the “communication clearing house” or hub. It may be necessary to use two or more hubs, one for panel control and another hub(s) for the mechanical system. This design will simplify the binding creation process and makes the system more scalable. For more information regarding the limitations placed on custom binding and recommendations regarding custom binding design, see “Understanding bindings” on page 130.

The bindings and variables shown in Table 31–Table 37 were those used in the tested UUKL system to send information between MP580s. The system programmer can use whatever bindings and variables are necessary.

### UUKL binding list (watchdog communication)

“Trouble signals and their restoration to normal shall be annunciated within 200 seconds of the occurrence of the adverse condition, fault, or the restoration to normal.” (UL-864: 49.2.b)

As there is no built in means of verifying inter-MP581 communication status, a programmed solution must be used. While a network variable “heartbeat” can be used to verify status, it can take up to 300 seconds for a communication failure to be noticed. This solution would fail to meet the requirement given in previous paragraph. The tested solution is based on a “watchdog” style where a continuously changing network variable triggers a timer every time it changes state. As long as the timer never expires, it is assumed that the two devices are communicating. In this fashion, a communication failure can be annunciated within 60 seconds.

Table 31 on page 124 shows an example of a custom binding list. One group binding binds MP580-2, which is the hub, to all other MP581s (for an explanation of group bindings, see “Understanding bindings” on page 130). The “watchdog” signal sent to the group is used by each receiver to confirm communications from the hub unit. The hub unit is able to validate communications from each of other MP581s using their individual “watchdog” signals. These bindings are point-to-point based. There may be two hubs in the system, one used with the FSCP and other within the mechanical system. The need for a second hub will be driven by the size of the mechanical system involved. Figure 71 on page 125 illustrates watchdog communication between MP581s in a hub-based system.

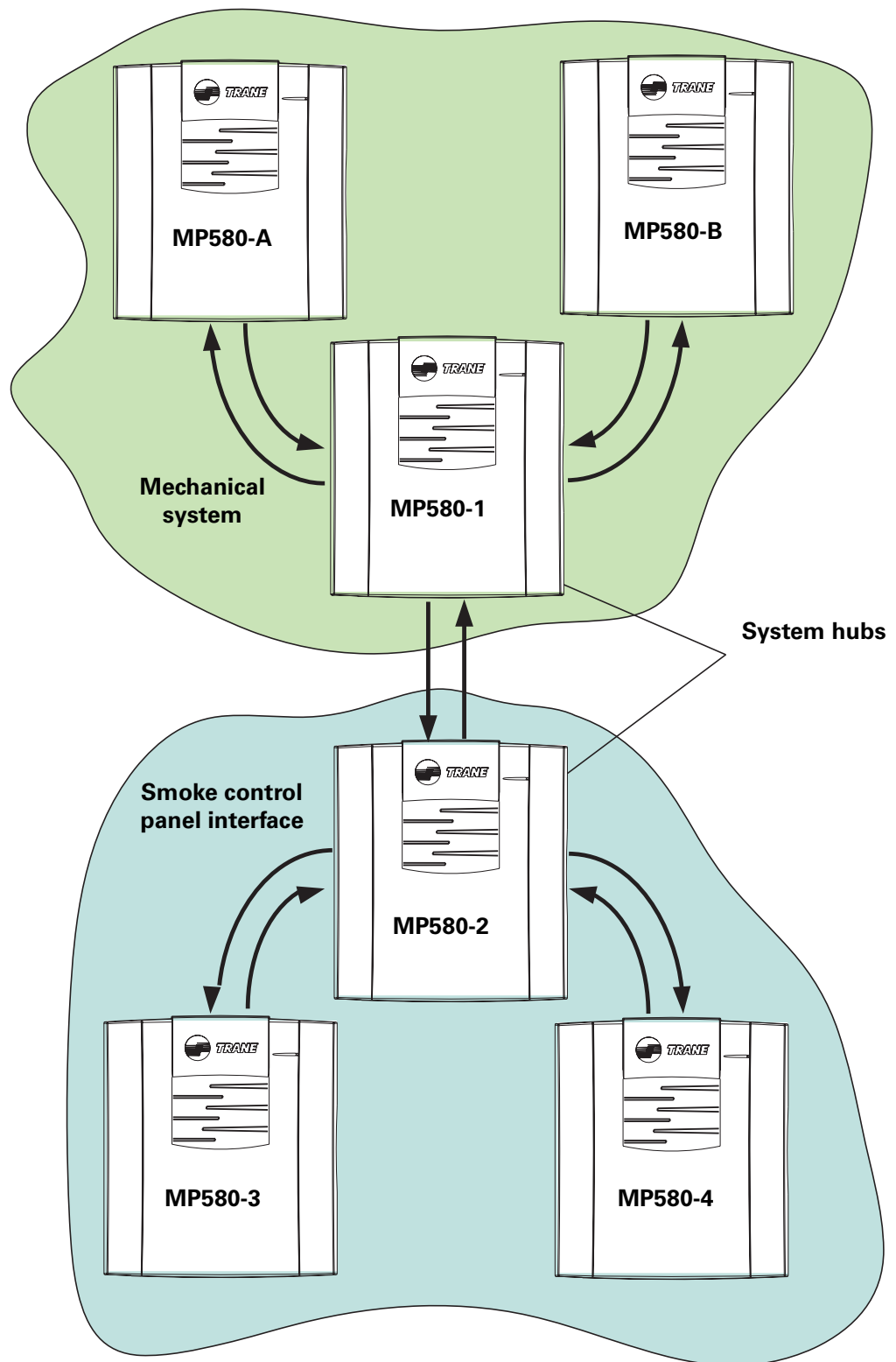
## Chapter 8 Network variable bindings

In Table 31, the term *multi-vibrator* is used to indicate a network variable whose state is changed regularly. The receiver expects this value to change state within a certain interval. If it does not, a communication fault is generated. The term *comm. status* is used to indicate a network variable whose state is dependent on that particular MP581's EX2 and BMTX communication status. If either are down, a communication fault is generated.

**Table 31. Watchdog communication alarm custom bindings**

Function	Originator	Network variable	Destination
Communication check from hub multi-vibrator	MP580-2	nvoSwitch36	Mechanical system/nviSwitch38
		nvoSwitch36	MP580-3/nviSwitch38
		nvoSwitch36	MP580-4/nviSwitch38
Communication check to hub multi-vibrator	Mechanical system	nvoSwitch38	MP580-2/nviSwitch34
Communication check to hub: FSCP unit multi-vibrator	MP580-3	nvoSwitch38	MP580-2/nviSwitch35
	MP580-4	nvoSwitch38	MP580-2/nviSwitch36
BMTX/EX2 communication check	Mechanical system	nvoSwitch39	MP580-2/nviSwitch37
BMTX/EX2 communication check to FSCP unit comm. status	MP580-3	nvoSwitch39	MP580-2/nviSwitch38
	MP580-4	nvoSwitch39	MP580-2/nviSwitch39



**Figure 71. Watchdog communication in a hub-based system**

### UUKL binding list (smoke alarm status)

Table 32 shows an example list of smoke alarm custom bindings. In order to comply with UL-864 annunciation and control requirements, smoke alarm signals are sent to the mechanical system, FSCP lamps, and audio alarms (Sonalerts). Smoke alarms specific to a zone are broadcast to annunciate smoke alarms regardless of control sequence. A general smoke alarm is broadcast to signal a switch from HVAC control mode to a smoke control mode. Floor alarms are sent as an analog value to comply with the subsequent alarms requirement.

**Table 32. Smoke alarm custom bindings**

Function	Originator	Network variable	Destination
Smoke alarm any	MP580-2	nvoSwitch02	Mechanical system /nviSwitch37
		nvoSwitch02	MP580-3/nviSwitch37
		nvoSwitch02	MP580-4/nviSwitch37
smokeAlarmFloor01	MP580-2	nvoSwitch05	Mechanical system /nviSwitch20
		nvoSwitch05	MP580-3/nviSwitch09
smokeAlarmFloor02	MP580-2	nvoSwitch06	Mechanical system/nviSwitch21
		nvoSwitch06	MP580-3/nviSwitch12
smokeAlarmFloor03	MP580-2	nvoSwitch07	Mechanical system/nviSwitch22
		nvoSwitch07	MP580-4/nviSwitch08
smokeAlarmFloor04	MP580-2	nvoSwitch08	Mechanical system/nviSwitch23
		nvoSwitch08	MP580-4/nviSwitch11
supplyDuctSmokeDetect	MP580-2	nvoSwitch09	Mechanical system/nviSwitch30
		nvoSwitch09	MP580-3/nviSwitch06
returnDuctSmokeDetect	MP580-2	nvoSwitch10	Mechanical system/nviSwitch31
		nvoSwitch10	MP580-4/nviSwitch05
stairDuctSmokeDetect	MP580-2	nvoSwitch11	Mechanical system/nviSwitch32
		nvoSwitch11	MP580-4/nviSwitch01
stairShaftSmokeDetect	MP580-2	nvoSwitch12	Mechanical system/nviSwitch33
smokeFloorAlarm	MP580-2	nvoPercent20	Mechanical system/nviPercent20
		nvoPercent20	MP580-3/nviPercent20
		nvoPercent20	MP580-4/nviPercent20

### UUKL binding list (FCSP override control)

Table 33 shows an example list of FCSP override custom bindings. Override commands from the FCSP are sent directly to the mechanical system.

**Table 33. FCSP override custom bindings**

Function	Originator	Network variable	Destination
supplyFanManControl	MP580-3	nvoPercent01	Mechanical system/nviPercent10
supplyDamperManFloor01	MP580-3	nvoPercent02	Mechanical system/nviPercent02
returnDamperManFloor01	MP580-3	nvoPercent03	Mechanical system/nviPercent03
supplyDamperManFloor02	MP580-3	nvoPercent04	Mechanical system/nviPercent04
returnDamperManFloor02	MP580-3	nvoPercent05	Mechanical system/nviPercent05
returnFanManControl	MP580-4	nvoPercent01	Mechanical system/nviPercent11
supplyDamperManFloor03	MP580-4	nvoPercent02	Mechanical system/nviPercent06
returnDamperManFloor03	MP580-4	nvoPercent03	Mechanical system/nviPercent07
supplyDamperManFloor04	MP580-4	nvoPercent04	Mechanical system/nviPercent08
returnDamperManFloor04	MP580-4	nvoPercent05	Mechanical system/nviPercent09
stairFanManControl	MP580-2	nvoPercent01	Mechanical system/nviPercent01

### UUKL binding list (actuator Open/Close or On/Off status)

Table 34 shows an example list of actuator status custom bindings. Actuator Open/Close or On/Off status is sent from the mechanical system directly to the FSCP.

**Table 34. Actuator status custom bindings**

Function	Originator	Network variable	Destination
supplyFanStatus	Mechanical system	nvoSwitch01	MP580-3/nviSwitch04
returnFanStatus	Mechanical system	nvoSwitch02	MP580-4/nviSwitch03
stairFanStatus	Mechanical system	nvoPercent01	MP580-2/nviPercent02
oaDamperStatus	Mechanical system	nvoPercent04	MP580-3/nviPercent01
raDamperStatus	Mechanical system	nvoPercent05	MP580-2/nviPercent01
eaDamperStatus	Mechanical system	nvoPercent06	MP580-4/nviPercent01
supplyDamperFloor01	Mechanical system	nvoPercent07	MP580-3/nviPercent02
returnDamperFloor01	Mechanical system	nvoPercent08	MP580-3/nviPercent03
supplyDamperFloor02	Mechanical system	nvoPercent09	MP580-3/nviPercent04
returnDamperFloor02	Mechanical system	nvoPercent10	MP580-3/nviPercent05
supplyDamperFloor03	Mechanical system	nvoPercent11	MP580-4/nviPercent02
returnDamperFloor03	Mechanical system	nvoPercent12	MP580-4/nviPercent03
supplyDamperFloor04	Mechanical system	nvoPercent13	MP580-4/nviPercent04
returnDamperFloor04	Mechanical system	nvoPercent14	MP580-4/nviPercent05

### UUKL binding list (actuator failure status)

Table 35 shows an example list of actuator failure status bindings. Actuator failure status is sent directly from the mechanical system to the FSCP.

**Table 35. Actuator failure status bindings**

Function	Originator	Network variable	Destination
supplyFanFail	Mechanical system	nvoSwitch20	MP580-3/nviSwitch05
returnFanFail	Mechanical system	nvoSwitch21	MP580-4/nviSwitch04
oadamperFail	Mechanical system	nvoSwitch22	MP580-3/nviSwitch03
radamperFail	Mechanical system	nvoSwitch23	MP580-2/nviSwitch01
eadamperFail	Mechanical system	nvoSwitch24	MP580-4/nviSwitch02
stairFanFail	Mechanical system	nvoSwitch25	MP580-2/nviSwitch02
supplyDamperFloor01Fail	Mechanical system	nvoSwitch26	MP580-3/nviSwitch07
returnDamperFloor01Fail	Mechanical system	nvoSwitch27	MP580-3/nviSwitch08
supplyDamperFloor02Fail	Mechanical system	nvoSwitch28	MP580-3/nviSwitch10
returnDamperFloor02Fail	Mechanical system	nvoSwitch29	MP580-3/nviSwitch11
supplyDamperFloor03Fail	Mechanical system	nvoSwitch30	MP580-4/nviSwitch06
returnDamperFloor03Fail	Mechanical system	nvoSwitch31	MP580-4/nviSwitch07
supplyDamperFloor04Fail	Mechanical system	nvoSwitch32	MP580-4/nviSwitch09
returnDamperFloor04Fail	Mechanical system	nvoSwitch33	MP580-4/nviSwitch10
checkSupervisedCircuits	Mechanical system	nvoSwitch40	MP580-2/nviSwitch04

### UUKL binding list (FSCP control)

Table 36 shows an example list of smoke control panel control custom bindings. Smoke control panel commands affect all MP581s panel control units.

**Table 36. Smoke control panel control custom bindings**

Function	Originator	Network variable	Destination
lampTest	MP580-2	nvoSwitch01	MP580-3/nviSwitch40
		nvoSwitch01	MP580-4/nviSwitch40
panel enable/disable	MP580-2	nvoSwitch03	MP580-3/nviSwitch36
		nvoSwitch03	MP580-4/nviSwitch36

## UUKL binding list (automatic self-test trigger and status)

Table 37 shows an example list of actuator failure status bindings. Only dedicated smoke control systems require a scheduled self-testing. Once the self-test is triggered, a status signal is sent to the panel trouble LED to blink.

**Table 37. Actuator failure status bindings**

Function	Originator	Network variable	Destination
systemSelfTest	MP580-2	nvoSwitch13	Mechanical system/nviSwitch36
selfTestEnable	Mechanical system	nvoSwitch04	MP580-2/nviSwitch05

## Custom binding report

It is strongly recommended that a custom binding report be done during and at the end of each custom binding session. The \*.csv (comma separated variables) is the most useful type for this report. It can easily be opened as a spreadsheet and formatted. If it is necessary to repair the custom bindings later, this file can be used as a resource to recreate the custom bindings.

## Understanding bindings

Network variable (NV) bindings provide a valuable way to share data on a LonTalk® link, but there are some limitations to keep in mind during the system design process. This section will help you understand the essential concepts involved in bindings, as well as their limitations.

The Echelon Corporation, the company that created LonWorks® and the LonTalk protocol, refers to bindings as *connections*. Echelon defines connections as “the implicit addressing established during binding. A connection links one or more logical outputs, network variables, to one or more logical inputs.”

Bindings provide a very efficient way to communicate. Data updates are sent from the output NV(s) to the input NV(s) *only when necessary*. When they are sent, they get to their destination quickly—typically, in less than a half-second.

An update to an output NV occurs when either of the following occur:

- A binary value changes state
- An analog value changes by more than a pre-programmed delta value
- A heartbeat timer expires

This peer-to-peer event-driven communications model often provides better performance than a master-slave and/or scan-type communications model. It is one of the key advantages of LonTalk.

A heartbeated network variable has a timer associated with it. When the timer expires, the heartbeated network variable is sent regardless of change of state or delta value of that network variable. Heartbeating functions both as an indicator of value “freshness” and an indicator of the quality of communications between two devices. From the perspective of a terminal device, value freshness is most important. From the perspective of the building automation system, communication quality is most

## **Node**

Nodes can be any LonTalk-compatible devices, such as appliances, switches, sensors, Tracer MP581s, and Tracer Summit BMTX BCUs, that are connected to a Trane LonTalk network. For the purposes of a UUKL-compliant system, a node is either a Tracer MP581 or a Tracer Summit BMTX BCU.

## **Network Address**

Nodes have network addresses, which are used to send messages and to determine if messages are destined for them. A node’s network address consists of three components:

- The domain to which the node belongs
- The subnet to which the node belongs within the domain
- The node number within the subnet

Domain, subnet, and node number are used to determine a custom bound variable’s origin and destination(s).

## **Binding types**

The custom bindings necessary to use in a smoke control system fall into the following two categories:

- Subnet/node: A one-to-one binding in which one output NV is bound to one input NV.
- Group: A one-to-many binding in which one output NV is bound to two or more input NVs.

## **Basic binding shapes and the hub/target system**

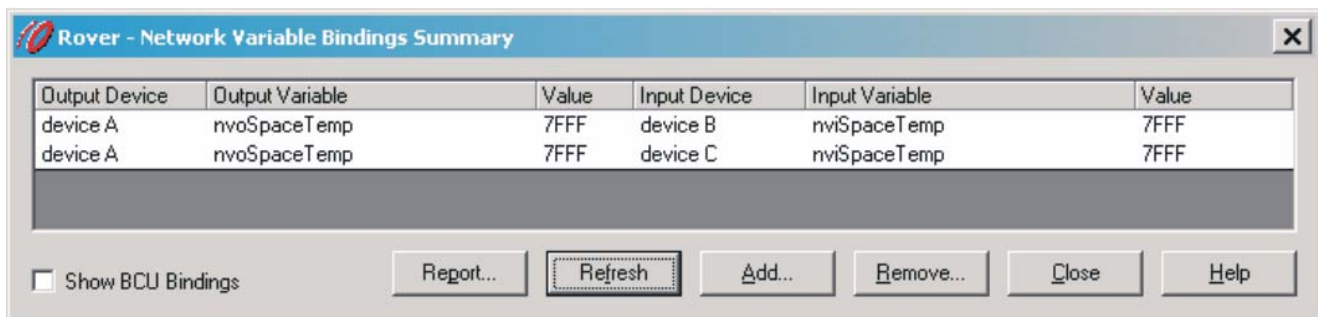
A one-to-one binding is always a subnet/node binding type. A binding with a fan-out shape is always a group binding type. A binding with a fan-in shape is always made up of several subnet/node bindings. Fan-in and fan-out bindings can have an unlimited number of members. Custom fan-in bindings are not necessary for the smoke control system. The target network variable will change value depending on which output network variable was last sent. There is no way to determine the origin of the information.

Echelon uses a hub/target system to describe the parts of a binding. As the term implies, there can be only one hub in a binding. The hub is the focal point of either a fan-out or fan-in binding. The targets are at the other end of the hub. It is important to remember that the hub and

targets can be either input NVs or output NVs, depending on the shape of the binding. For a one-to-one binding, the hub/target model loses its meaning, and either side of the binding could be the hub or the target.

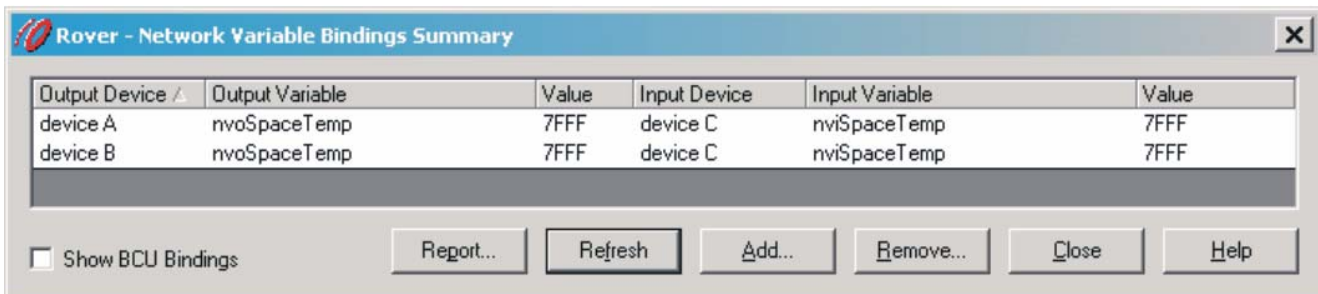
The Rover service tool does not indicate the shape or the type of the binding. It is up to you to look at the binding summary and determine the shape. Figure 72 and Figure 73 show examples of a three-member fan-out binding and a three-member fan-in binding as they would look in Rover. Notice that the hub variable is repeated for each target variable.

**Figure 72. Rover's view of a fan-out binding**



Output Device	Output Variable	Value	Input Device	Input Variable	Value
device A	nvoSpaceTemp	7FFF	device B	nviSpaceTemp	7FFF
device A	nvoSpaceTemp	7FFF	device C	nviSpaceTemp	7FFF

**Figure 73. Rover's view of a fan-in binding**



Output Device	Output Variable	Value	Input Device	Input Variable	Value
device A	nvoSpaceTemp	7FFF	device C	nviSpaceTemp	7FFF
device B	nvoSpaceTemp	7FFF	device C	nviSpaceTemp	7FFF

### Address table

A device's address table resides in non-volatile memory. The address table serves several functions. Its main purpose is to hold the network (DSN) or group addresses of the devices that will receive outgoing binding data. Subnet/node bindings use DSN destinations in the sending device's corresponding address table entries. Group bindings use group address destinations in the sending device's corresponding address table entries. Another purpose of the address table is to define group membership for receiving devices. This allows a receiving device in a group binding to know that it is a member of a given group so that it can accept or reject bound message packets accordingly. A LonWorks device can be a member of up to 15 groups, a limit that is directly associated with the size of the address table. *The limit of 15 address table entries will be a constraint when designing bindings.*



The address table consists of the following elements (refer to column headings in Table 38):

- **Use Domain at Index:** This number represents a pointer or reference to a table entry in the Domain table. For Trane devices, the value at index (or row) 0 will be a decimal 17.
- **Group Number or Subnet Address field:** The function varies depending on the binding type. For group bindings, the group number is stored here. For subnet/node bindings, the subnet address is stored here.
- **Group Member at Node Address field:** This varies depending on the binding type. The group member specifies a unique number for each member of a group binding.
- **Group Size field:** This specifies the total number of members in the group binding.

The address table in Table 38 shows a subnet/node binding at index 0, which lists a device at DSN 17-1-8 as the destination. And it shows that the device is the second member of Group 1, which has a total of three members.

**Table 38. Address table**

Addr index	Binding type	Use Domain at Index	Group Number or Subnet Address	Group Member of Node Address	Group Size
0	subnet/node	0	1	8	n/a
1	group	0	1	2	3
2	unbound				
3	unbound				
14	unbound				

## Designing bindings

On a LonWorks job, binding connections should be designed and documented just like wiring connections are designed and documented on shop drawings. Follow these rules, limits, and the methodology provided when designing bindings:

### Binding rules and limits

1. Bindings can be made only between NVs that have the same network variable type (SNVT or UNVT).

For example, nvoSpaceTemp is of type SNVT\_temp\_p and nviSpaceTemp is also of type SNVT\_temp\_p, so these two variables can be bound. Rover takes care of matching network variable types for you, but during design, this fundamental rule should be kept in mind.

2. Unique subnet/node binding types consume an address table entry on the sending device only.

A unique subnet/node binding type is a specific path from device X to device Y. Any number of actual network variable bindings could be built upon this path (see below). Regardless of the number of bindings built on a given path, only one address table entry will be consumed on the sending device. Note that this rule applies to subnet/node bindings that are part of one-to-one binding shapes or fan-in binding shapes.

3. Unique group binding types consume an address table entry on all devices in the group.

A unique group binding type is a specific fan-out path from device X to a specific set of target devices (for example, Y and Z). Any number of actual network variable bindings could be built upon this path (see below). If another sending device and/or another set of target devices is necessary, a new group is needed and another address table entry will be consumed in each group member.

4. Each LonWorks device has a maximum of 15 address table entries.

This limit applies to all LonWorks devices: Neuron-based devices, host-based devices (including the BCU), and hybrid devices. Note that the Tracer VV550/551 is an exception; it has only 14 available address table entries.

5. A maximum of 256 groups are possible per domain.

This limit should not be a factor in most designs.

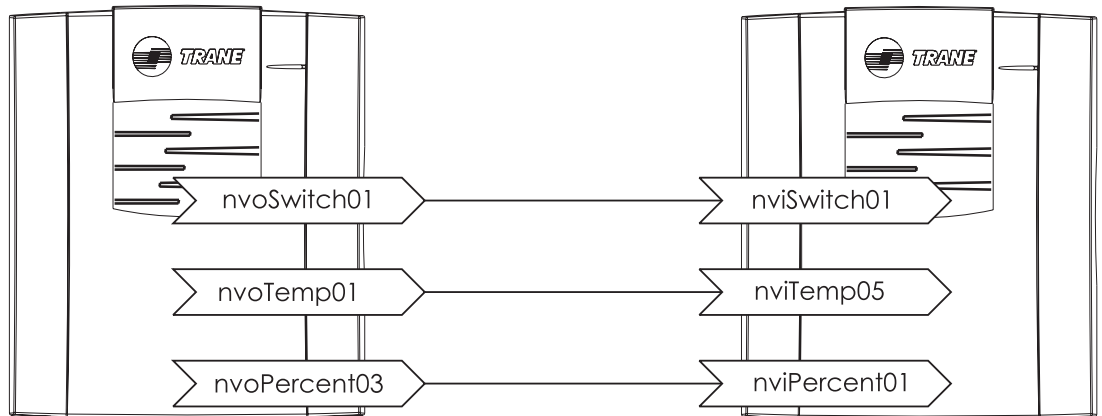
6. A group binding that uses acknowledged service can have a maximum of 64 members. A group binding that uses unacknowledged or unacknowledged repeated service can have an unlimited number of members.

### **Stacking bindings on unique binding paths**

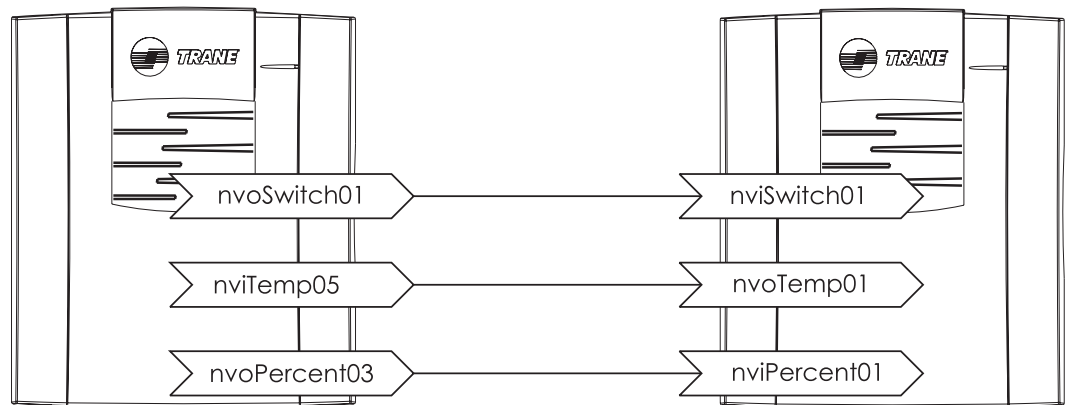
Once a binding has been created, a unique path exists that is defined in the address tables. It is important to understand that these unique paths can be reused by additional bindings without consuming additional address table entries.

A unique path is possible for subnet/node binding types (one-to-one or each piece of a fan-in) and group binding types (fan-out). A unique path is defined by a sending hub and a specific set of receiving target devices.

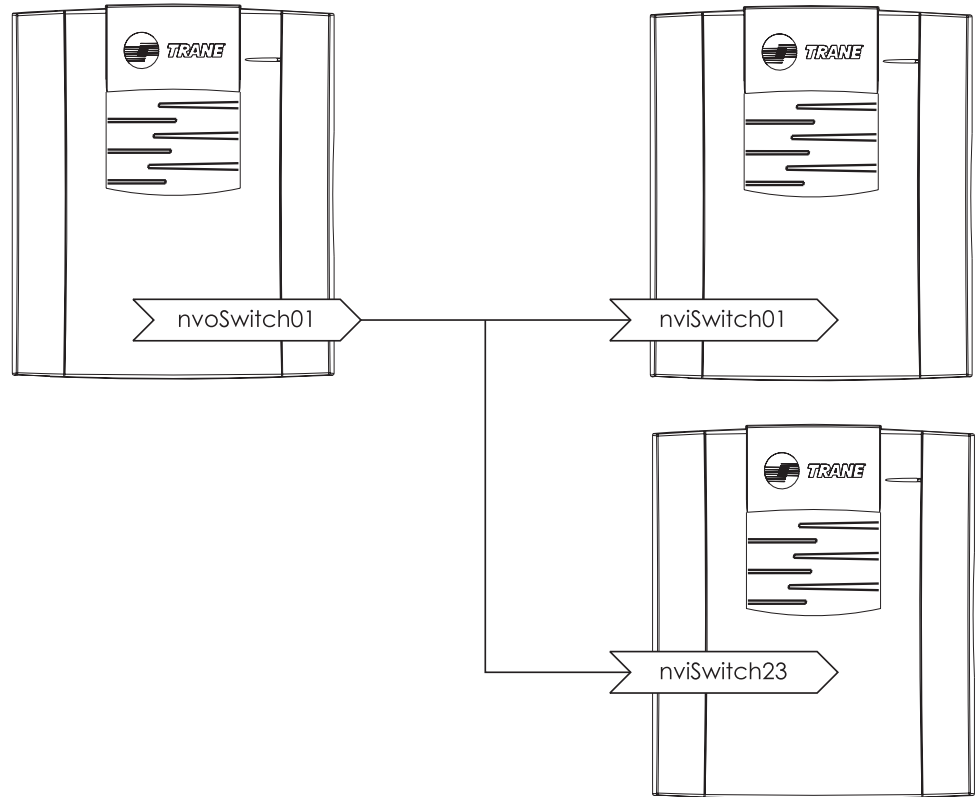
The simplest unique path is that shown in Figure 74. The three bindings below will consume one entry, the domain/subnet/node of MP581-B, in MP581-A's address table. They will not consume any entries in MP581-B's address table. Only MP581-A is the transmitter in this example. This is a subnet/node binding. A good analogy would be that the road between MP581-A and MP581-B has already been laid down (in one direction). Any other information needed to flow between those two devices has a well defined route already available.

**Figure 74. One-way subnet/node binding**


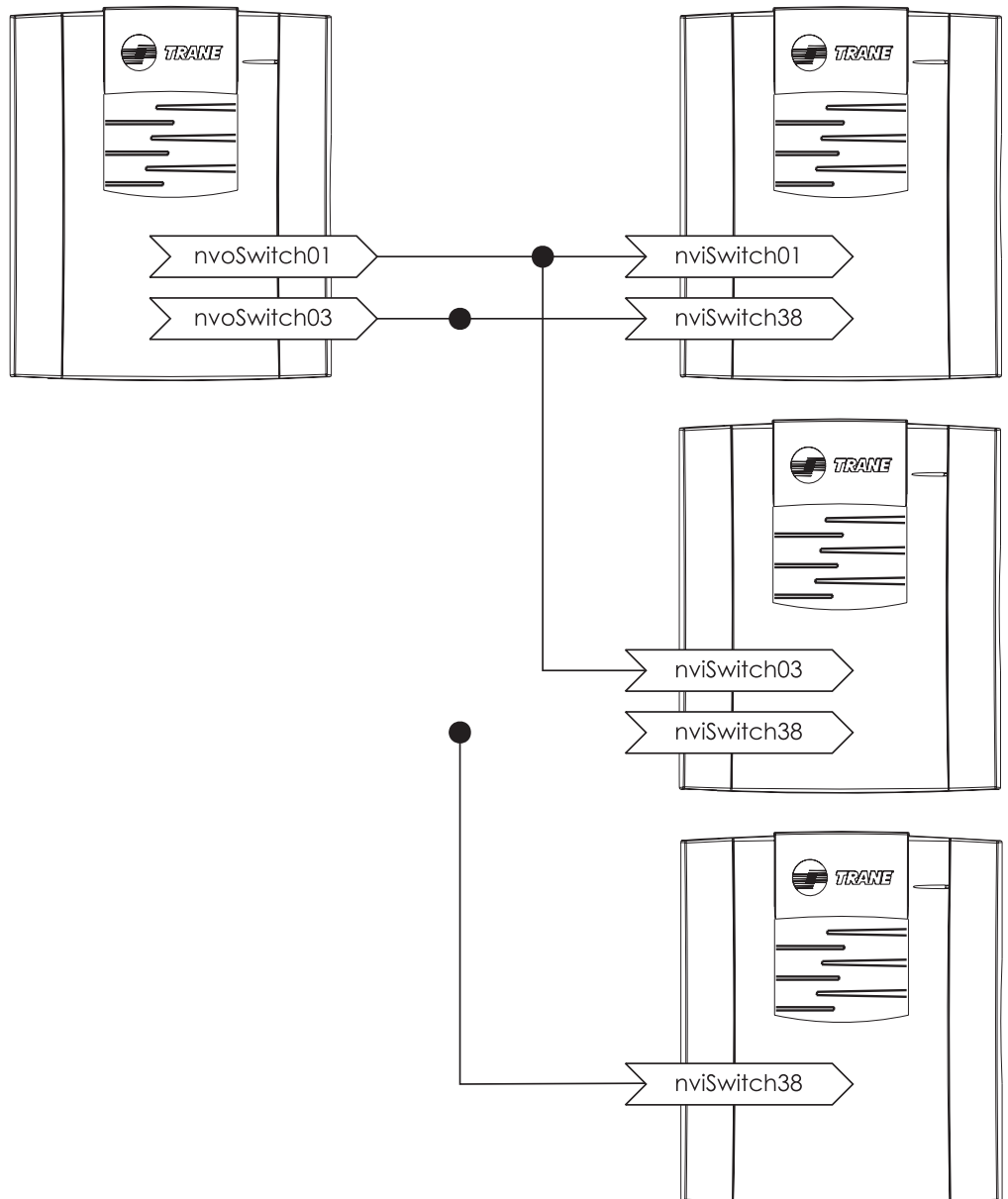
In the example shown in Figure 75 on page 135, the custom bindings consume an address table entry in both MP581-A and MP581-B. Both MP581s are now transmitters of data. Both are subnet/node bindings.

**Figure 75. Two-way subnet/node bindings**


A group binding is shown in Figure 76. In this case, in every member's address table, an entry number and group number are listed. A group binding made in this way is also called a *fan-out* binding.

**Figure 76. Group binding**

Groups are unique. Two unique groups are shown in Figure 77. One consists of MP581-A, B, and C while the other has members MP581-A, B, C, and D. Even though one is a subset of the other, it is set apart by having a different amount of members. In this case, MP581-A, B and C have two group entries in their respective address table. MP581-D has just one group entry in its address table.

**Figure 77. Group binding uniqueness**


When a group binding is made, all members of the group have an entry in their address table defining which group, what their member number is within that group and size of the group. Once this entry is made, any member of the group can now transmit information to the other members within that particular group. Figure 78 illustrates this concept.

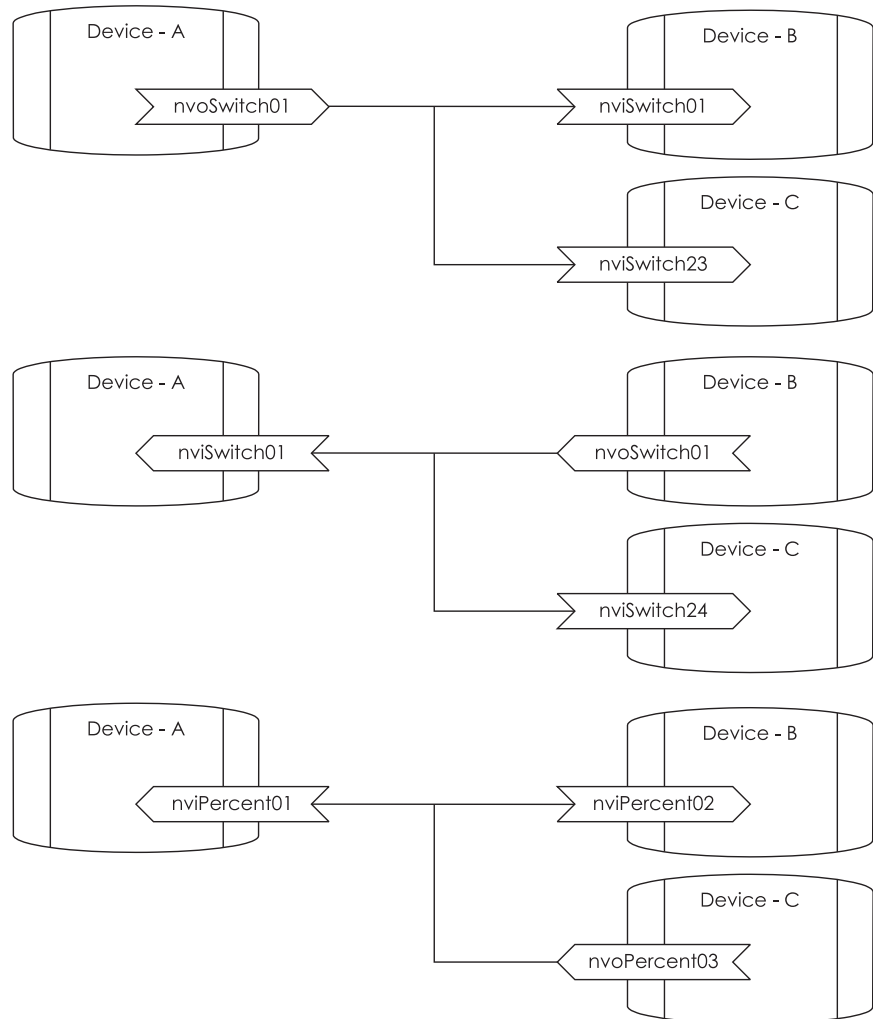
For example, the user defines a group binding which has Device A sending nvoSwitch01 to Device B and Device C. When the binding is

## Chapter 8 Network variable bindings

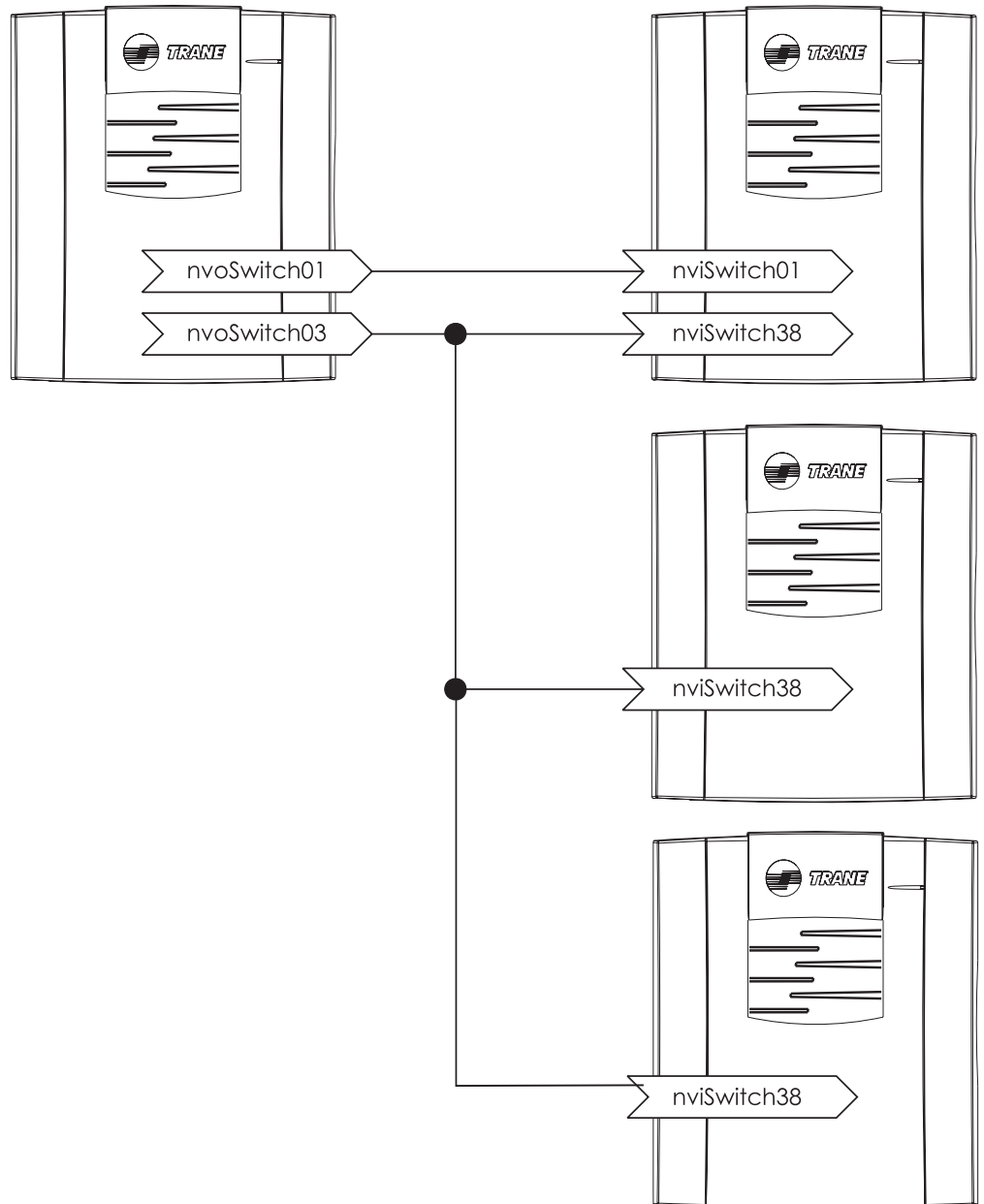
made, each member of the group has a entry made in its address table. For this example, all the devices are in Group 1. Now the user defines a second group binding with Device B transmitting nvoSwitch01 to Device A and Device C.

But this definition has exactly the same membership list as in Group 1. No additional entry into the address table is necessary to define the group. All three of the group binding configurations in Figure 78 use the same entry in each devices address table.

**Figure 78. Group bindings with the same membership**



Mixed bindings are illustrated in Figure 79. For this configuration, MP581-A, B, C and D have one group entry in their address tables. MP581-A has 1 subnet/node entry in its address table.

**Figure 79. Mixed subnet/node and group bindings**



***Chapter 8 Network variable bindings***



## Appendix A

# References

---

Huggett, C. 1980. *Estimation of Rate of Heat Release by Means of Oxygen Consumption Measurements, Fire and Materials*, Vol. 4, No. 2, June.

Klote, J.H. 1994. *Method of Predicting Smoke Movement in Atria With Application to Smoke Management*, National Institute of Standards and Technology, NISTIR 5516.

Klote, J.K. and Milke, J.A. 1992. *Design of Smoke Management Systems*, American Society of Heating, Refrigerating and Air-conditioning Engineers, Atlanta, GA.

NFPA 1995. *Guide for Smoke Management Systems in Malls, Atria, and Large Areas*, NFPA 92B, National Fire Protection Association, Quincy, MA.

NFPA 1996. *Recommended Practice for Smoke Control Systems*, NFPA 92A, National Fire Protection Association, Quincy, MA.

NFPA 1996. *Standard for the Installation of Air Conditioning and Ventilating Systems*, NFPA 90A, National Fire Protection Association, Quincy, MA.

NFPA 1997. *Life Safety Code*, NFPA 101, National Fire Protection Association, Quincy, MA.

SFPE 1995. *Fire Protection Engineering Handbook*, National Fire Protection Association, Quincy, MA.

Tamura, G.T. 1994. *Smoke Movement & Control in High-Rise Buildings*, MA.

UL 555S, Standard for Smoke Dampers, Underwriters Laboratories Inc., 333 Pfingsten Road, Northbrook, IL 60062.

UL 864, Standard for Control Units and Accessories for Fire Alarm Systems, Underwriters Laboratories Inc., 333 Pfingsten Road, Northbrook, IL 60062.



***Appendix A References***





**Trane**  
**A business of American Standard Companies**  
**[www.trane.com](http://www.trane.com)**

*For more information, contact your local Trane  
office or e-mail us at [comfort@trane.com](mailto:comfort@trane.com)*

---

Literature Order Number	BAS-APG001-EN
File Number	SV-ES-BAS-APG001-0906
Supersedes	SV-ES-BAS-APG001-09-00
Stocking Location	Inland

---

Trane has a policy of continuous product and product data improvement and reserves the right to change design and specifications without notice. Only qualified technicians should perform the installation and servicing of equipment referred to in this publication.